

Parts Identification

6950 Twin Cutter

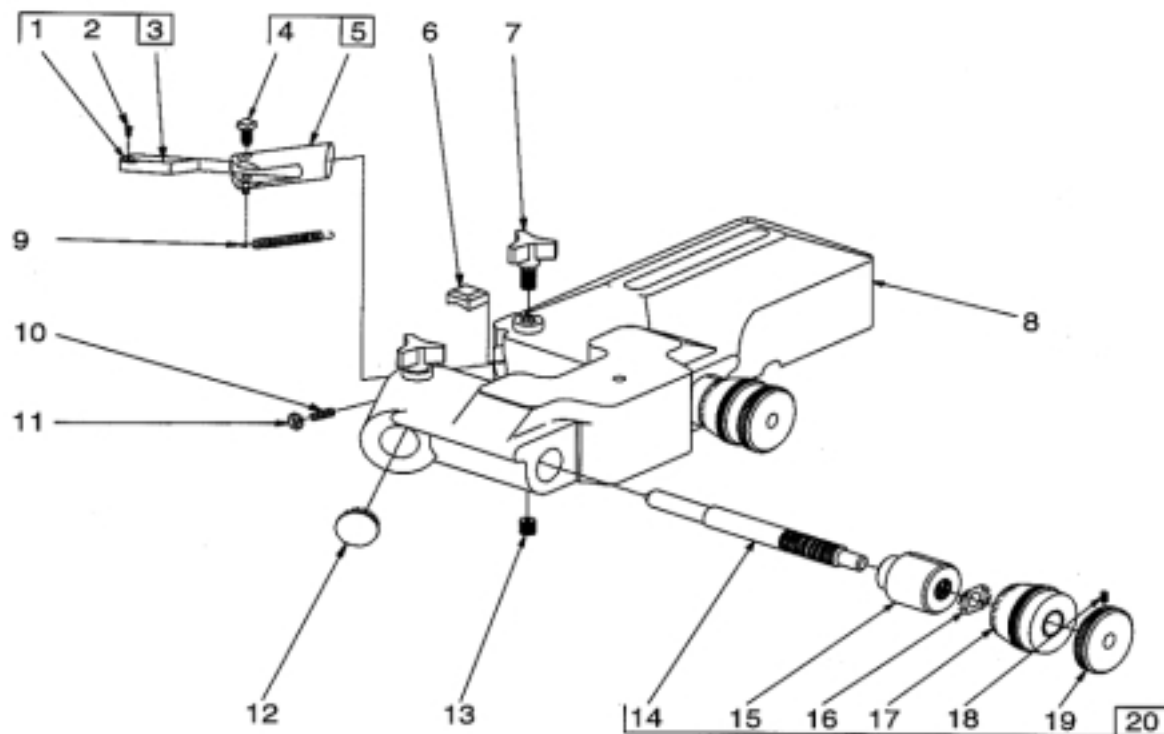

Item	Qty	Part No.	Description
*1	2	906918	Carbide Insert, Positive Rake
**	2	906914	Carbide Insert, Negative Rake
	2	906499	Screw, #4-40 X .25 Oval Head
*3	1	925968	Holder, Tool Bit, RH, Positive Rake
*	1	925969	Holder, Tool Bit, LH, Positive Rake
**	1	910701	Holder, Tool Bit, RH, Neg. Rake
**	1	910702	Holder, Tool Bit, LH, Neg. Rake
4	2	909249	Screw, Square Head Set
5	1	910650	Tool Holder, Left Hand
	1	910651	Tool Holder, Right Hand
6	2	928584	Gib, Brass, Tool Holder
7	1	906854	Screw, Lock
8	1	928572	Twin Cutter Housing
9	1	906905	Spring
10	2	909879	Screw, Locating
11	2	903528	Nut, Hex
12	2	906977	Plug, Dot

Item	Qty	Part No.	Description
13	2	906109	Screw, 3/16-16 Set
14	2	906908	Rod, Dial
15	2	906906	Plug, Dial
16	2	906929	Washer, Spring
17	2	906907	Dial, Micrometer
18	2	903338	Screw, Set
19	2	906923	Knob, Dial Rod
20	1	906901	Dial Assembly

Note: These parts are not included with the 6950 Twin Cutter tool.

For a complete assembly, order one of the following:
 *28800 twin cutter with positive rake tool holders and bits.
 **29800 twin cutter with negative rake tool holders and bits.

Automotive Equipment Sales and Service
 2426 Arbuckle
 Dallas, Texas 75229
 In the Dallas - Ft Worth Area (972) 241-6404
 Nationally (800) 749-5990
 Fax: (972) 241-6433
www.autoess.com