

# EM 8070

---

Versione 3.0 del 09/00

Italiano

Manuale d'uso

English

Operator's manual

Français

Manuel d'utilisation

Deutsch

Betriebsanleitung

Español

Manual de uso

# INTRODUCTION

The purpose of this manual is to provide the owner and operator of this machine with a set of safe and practical instructions for the use and maintenance of the balancing machine.

Follow all of the instructions carefully and your machine will assist you in your work and give long-lasting and efficient service, in keeping with CORGHI traditions. The following paragraphs define the levels of danger regarding the machine, associated with the warning captions found in this manual.

## **DANGER**

**Refers to immediate danger with the risk of serious injury or death.**

## **WARNING**

**Dangers or unsafe procedures that can cause serious injury or death.**

## **ATTENTION**

**Dangers or unsafe procedures that can cause minor injuries or damage to property.**

Read these instructions carefully before using the machine. Keep this manual and the illustrated material supplied with the machine in a folder near the place of operation, where it is readily accessible for consultation by the machine operator. The technical documentation supplied is considered an integral part of the machine; in the event of sale all relative documentation must remain with the balancing machine.

The manual is only valid for the machine model and serial number indicated on the nameplate applied to the machine itself.



## **WARNING**

**Adhere to the contents of this manual: Corghi declines all liability in the case of actions not specifically described and authorised in this manual.**

## **NOTE**

Some of the illustrations in this manual have been taken from photographs of prototypes; the standard production model may differ slightly in certain respects. These instructions are for the attention of personnel with basic mechanical skills. We have therefore condensed the descriptions of each operation by omitting detailed instructions regarding, for example, how to loosen or tighten the fixing devices on the machine. Do not attempt to perform operations unless properly qualified and with suitable experience. In case of need, please contact our nearest authorised Service Centre for assistance.

---

*All rights reserved. No part of this publication may be translated, stored in an electronic retrieval system, reproduced, or partially or totally adapted by any means (including microfilm and photostats) without prior permission.*

*The information contained herein may be subject to modifications without prior notice.*

# TRANSPORT, STORAGE AND HANDLING

The **basic** balancing machine packaging consists of 1 wood package containing:

- the balancing machine unit (P, fig.4);
- the support cabinet and head unit plates (A, fig.5); the monitor in its packing; accessories.
- the support tube and wheel guard (A, B, fig.6).
- Before installation, the balancing machine must be transported in its original packaging, keeping it in the position marked on the packaging. It can be transported by placing the box on a wheeled trolley or by inserting the forks of a fork-lift truck into the openings in the pallet (fig.1).
- Packing dimensions.

Length (mm)	Depth (mm)	Height (mm)	Weight (kg)	Packing weight (kg)
1470	850	1150	207	50

- Ambient conditions in place of storage:

- relative humidity from 20% to 95%;
- temperature from -10° to +60°C.



## ATTENTION

**Do not place other items on top of the two packs, as this may result in damage.**

After installation, the machine can be moved using the following methods:

- with a crane, using special equipment that holds the machine at the lifting points (fig.2);
- inserting the forks of the lift truck under the machine so that the centre of the forks correspond approximately to the centre line of the cabinet (fig.3).



## WARNING

**Always unplug the power supply lead from the socket before moving the machine.**



## ATTENTION

**Never apply force to the spin shaft when moving the machine.**

GB

# INSTALLATION



## WARNING

**Carry out the unpacking, assembly and installation operations described in this heading with great care.**

**Failure to observe these instructions may result in damage to the machine and injury to the operator or other persons.**

Remove the original packing material, after having positioned it as shown on the outside and **keep intact so that the machine can be safely shipped at a later date if necessary.**



## ATTENTION

**The regulations in force concerning safety at work must be complied with when choosing the installation position.**

**In particular, the machine must be only be installed and used in protected environments where there is no risk of dripping onto it.**

Ambient conditions in place of operation:

- relative humidity from 30% to 80% (without condensate);
- temperature from 0° to +50°C.



## ATTENTION

**For the technical specifications, warnings, maintenance and all other information concerning the monitor, refer to the relative operator manuals supplied with the machine's documentation.**



## WARNING

**The machine must not be operated in potentially explosive atmospheres.**

**IMPORTANT:** for correct, safe use of the equipment, users must ensure a lighting level of at least 300 lux in the place of use.

If the machine is supplied with a number of separate parts that require assembly, follow the assembly procedures described below.

### Fitting the head with the monitor (fig.5)

- Tighten the retainer screw (F, fig.5) and the relative lock-nut on the head support upright plate.
- Place the head (A, fig.5) on the upright behind the weight-holder lid (E, fig. 5), fitting the pin into the hole; the monitor screen must be facing towards the front of the machine.
- Check that the head will turn freely through about 30° ; this means that the rotation stop has fitted into the seat provided correctly.
- Fix the head rotation pin into its seat, fitting the snap ring, the washer and the M6 screws (G, fig. 5)

- Unscrew the fixing screws and remove the front panel and rear cover (B, C, fig. 5).
- Unscrew the four fixing screws and remove the connector protection plate at the base of the upright (rear of the machine).
- Working from the inside of the head, screw the M4 stud bolts complete with pads on the threaded insets on the sides of the head (H, fig. 5). The stud bolts should be screwed in place so that the monitor can be easily inserted inside the head.
- Remove the monitor from its packaging and remove its stand.
- Insert the monitor behind the head so that the screen rests on the front panel (fig.5c); the monitor must have its on/off switch (on the front) in on position.
- Connect the signal cable to the socket on the rear of the monitor and insert it into the upright, passing it through the opening in the top of the upright.
- Take the cable already inserted and connect it to its connector (fig.5d).
- The monitor power supply lead (ordinary mains plug) must be connected to the socket on the side of the upright (the one without splash-guard).
- Switch on the balancing machine.
- Adjust the monitor image using the controls on the front, and those on the rear if necessary. For information on how to make the adjustment, refer to the manual monitor supplied inside its packaging.
- **Switch off the balancing machine.**
- Replace the front panel and fix it in place with the screws removed previously. The wires leading from the front panel must pass below the monitor support surface and must be secured with band clamps.
- The cables leading from the front panel must pass below the monitor support surface and must be fixed in place using band clamps.
- Then insert these cables through the window in the top of the upright.
- Working through the window in the base of the upright, take the cables already inserted and connect them to their respective connectors (fig.5d). To avoid wiring errors, the connectors are of different sizes. Any excess cable length can be stowed inside the upright.
- **Important:** connect the connection unit of the yellow-green ground wire to the head.
- By adjusting the M4 stud bolts on the sides of the head from the outside, bring the locking pads into contact with the monitor so that they are symmetrically positioned.
- Working from the inside of the head, tighten the lock-nuts on the M4 stud bolts.
- Fit the plugs provided into the riveted insets at the sides of the head.
- Replace the rear cover and secure it with the screws removed previously.

### Fitting the external sensor and guard (fig.6)

- Unscrew the locking nuts of the two screws in the holes of the support pin and remove the screws.
- Fit the guard tube (A, fig.6) into the support pin, lining up the two sets of holes.
- Fit the two screws into the holes and lock the tube to the support by tightening the relative nuts.
- Fix the external sensor support bracket, keeping the concave part facing upward, on the tube of the guard, using the two screws provided (D, fig.6).

- Fit the round pin on the sensor body into the hole in the support and fix it with the enclosed snap ring (D, E, F, fig.6).
- Place the wheel guard (B, fig.6) on the tube and fix the wheel guard by snapping the seven clamping elements into their seats (C, fig.6). Pass the sensor cable through the two rear snap-in clamping elements so that it is concealed from view.
- Then connect the sensor cable connector to the socket close to the mains sockets.
- Assemble the 5 flange holder pins as shown in fig.4b.

After the machine has been assembled it should be installed in the prestabilised position, making sure that the surrounding spaces correspond to the minimum values indicated in figure 8.

The balancing machine must be placed in a stable position; to ensure this, adjust the bolt in the rear left-hand corner of the base (after adjusting, tighten using the lock-nut) (fig.7).

### Instructions for fixing to the floor (fig.7a)

- Remove the flexible supports from the machine by unscrewing the fixing screws. Remove the metal inserts from inside the rubber feet.
- Position the machine in the point required and make marks on the floor where the fixing holes are to be made.
- Make three holes in the floor, insert the expansion plugs and position the machine in line with the holes.
- Fit the supporting feet and the fixing screws with the relative washers in the order shown in the fig. 7a.
- Tighten the screws until the rubber feet and PVC washer are slightly compressed.
- Adjust the adjustable foot so that the machine rests firmly on the ground and then tighten the lock nut on the adjuster screw.

### Main operational components of the machine (fig.4)

- A** automatic diameter and distance measuring arm
- B** automatic width measuring arm
- C** head
- D** 14" color monitor
- E** KIS
- F** Start key
- G** Stop key
- H** flange-holder
- I** weight-holder cover
- J** wheel support shaft
- K** master switch
- L** handling holes
- M** wheel guard
- N** QL control pedal (optional accessory)
- O** ROD run-out detector (optional accessory)

# ELECTRICAL HOOK-UP

On request the balancing machine can be set up by the manufacturer to operate with the power supply available in the place of installation. The set-up details for each individual machine are given on the machine data plate and on a special label attached to the power supply connection cable.



## WARNING

**All operations required for the electrical hook-up of the machine must be carried out exclusively by a qualified electrician.**

- The electrical supply must be suitably sized in relation to:
  - absorbed power specifications indicated on the machine dataplate.
  - the distance between the machine and the power supply hook-up point, so that voltage drops under full load do not exceed 4% (10% in the case of start-up) below the rated voltage specified on the dataplate.
- The user must equip the machine with the following:
  - a dedicated power plug in compliance with the relevant electrical safety standards.
  - a suitable circuit-breaker (residual current set to 30 mA) on the mains connection
  - power line fuses in accordance with specifications in the main wiring diagram of this manual.
  - a suitable earthing system installed on the workshop mains line
- To prevent unauthorised use of the machine, always disconnect the mains plug when the machine is not used (switched off) for extended periods of time.
- If the machine is connected directly to the power supply by means of the main electrical panel and without the use of a plug, install a key-operated switch or suitable lock-out device to restrict machine use exclusively to qualified personnel.



## WARNING

**A good ground connection is essential for the correct functioning of the machine. NEVER connect the machine ground wire to a gas pipe, water pipe, telephone cable or other unsuitable objects.**

GB

# PNEUMATIC HOOK-UP

**The pneumatic hook-up is only necessary if the ROD and QL accessories are present.**

- The connection to the workshop's compressed air system must guarantee a minimum pressure of 8 bar; lower pressures might prevent correct operation of the release cylinder, leading to difficulties in releasing the wheel from the machine shaft.
- The union for connection to the compressed air system is of universal type and thus no special or additional attachments are required. A high pressure rubber hose with inside diameter 6 mm and outside diameter 14 mm must be connected to the toothed union using the hose clamp supplied with the machine.

## SAFETY REGULATIONS



### WARNING

**Failure to observe these instructions and the relative danger warnings can cause serious injury to the operator or other persons.**

**Do not use the machine until you have read and understood all the danger/warning/attention notices in this manual.**

This machine must be used only by qualified and authorised personnel. A qualified operator is construed as a person who has read and understood the manufacturer's instructions, is suitably trained, and is conversant with safety and adjustment procedures to be adhered to during operations. Operators are expressly forbidden from using the machine under the influence of alcohol or drugs capable of affecting physical and mental capacity.

The following conditions are essential:

- read and understand all the instructions on how to use the machine;
- have a thorough knowledge of the capacities and characteristics of the machine;
- keep unauthorised persons well clear of the area of operation;
- make sure that the machine has been installed in compliance with established legislation and standards;
- make sure that all machine operators are suitably trained, that they are capable of using the machine correctly and that they are adequately supervised during work;
- do not touch power lines or the inside of electric motors or other electrical equipment until the power has been disconnected;
- read this manual carefully and learn how to use the machine correctly and safely;
- always keep this manual in a place where it can be readily consulted when working with the machine and do not fail to refer to the manual whenever in need of confirmation or explanations.

 **WARNING**

**Do not remove or deface the Safety, Danger or Instruction decals. Replace any missing or illegible Safety, Danger or Instruction decals. Replacement decals can be obtained from your nearest CORGHI dealer.**

- When using and carrying out maintenance on the machine, observe the unified industrial accident prevention regulations for high voltage industrial equipment and rotating machinery.
- Any unauthorised alterations made to the machine automatically release the manufacturer from any liability in the case of damage or accidents as a result of such alterations. Specifically, tampering with or removing the machine's safety devices is a breach of the regulations for industrial accident prevention.

 **WARNING**

**During work and maintenance operations, always tie up long hair and do not wear loose clothing, ties, necklaces, wristwatches or any other items that may get caught up in the moving parts.**

Key to warning and instructions labels



Never apply force to the spin shaft when moving the machine.



Unplug the power supply cable before carrying out maintenance/ assistance work on the machine.

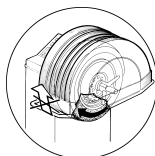

Do not lift up the guard when the wheel is turning.

**GB**

# GENERAL CHARACTERISTICS

- Variable balancing speed (from 60 to 98 rpm depending on the wheel):
  - optimises wheel spin times by minimising them
  - reduces risk due to rotating parts
  - allows energy saving
- Wheel placed further forward towards the operator for easier placing of the adhesive weights.
- Automatic sensors for measuring wheel distance, diameter and width and for application of the adhesive weights in Alu P programs
- Automatic wheel clamping at the end of the spin
- Automatic and pedal-operated brake on wheel-holder shaft
- STOP button to stop the machine immediately
- Side flange holder cabinet
- Cover with tray to take the weights and the most widely used accessories
- Mini-anvil for repairing clip weights
- Automatic start by pushing down on lowered wheel guard
- 14" high resolution colour monitor: indispensable for the execution of new programs
- Graphics allowing operators to learn to use the machine quickly and easily
- Knob(KIS) for entering data and for program selection
- Interactive Help function gives explanations about the program in which it is recalled.
- Possibility of selecting different languages
- Processing unit with several microprocessors (16 bit)
- Imbalance value detection precision: 1 gram (1/10 oz.)
- Wide selection of programs so that the machine is easy to use immediately
- Imbalance display in grams and ounces
- Imbalance display rounding setting.
- types of balancing available:
  - *Standard* dynamic on both sides
  - *Alu / Alu P* seven different routines for aluminum rims
  - *Motorcycle dynamic* dynamic on both sides of motorcycle wheels
  - *ALU motorcycle* dynamic on both sides of aluminum motorcycle wheels
  - *Static* on a single side
- "**Mobile planes**" program (in ALU P) for using multiple five gram weights, i.e.: available without the need for partial cuts
- "**Hidden weight**" program (in ALU P) in order to sub-divide the outer plane balancing adhesive weights into two equal weights positioned behind the rim spokes
- "**Weight division**" program (motorcycle programs) to divide the weight into two equivalent values to be placed on either side of the spoke.
- "**OPT flash**" program for rapid optimisation of operating noise (standard version of OPT is also available on request).
- General utility programs:
  - Calibration
  - Personalisation
  - Partial and total spin number counter

- Setting of the 3 most widely used programs
- Servicing
- Self-diagnostics
- Three separate working environments, allowing three different operators to work in parallel with no need to set the data again.
- Car accessory data bank, specifying the best way of fitting a wheel on the balancing machine.
- RPA, automatic wheel positioning in the position where the balancing weight has to be applied.
- Quick Lock, automatic wheel clamping (optional)
- ROD, wheel eccentricity detector (optional)
- Printer, prints the imbalance values (optional)
- Voice synthesis (on request)

## TECHNICAL SPECIFICATIONS

- Supply voltage ..... 110/115/230 V  $\pm$ 10%
- Power draw ..... 420 W
- Balancing speed ..... 60  $\div$  98 rpm
- Maximum imbalance value calculated ..... 999 grams
- Average spin time (with 5x14" wheel) ..... 5.5 sec
- Shaft diameter ..... 38 mm
- Work ambient temperature ..... from 0 to 50°C
- *Machine dimensions (fig.9)*
  - width with guard ..... 1215 mm
  - depth with guard closed ..... 1160 mm
  - depth with guard open ..... 1445 mm
  - height with guard close ..... 1490 mm
  - height with guard open ..... 1710 mm
- *Programming parameters*
  - rim width ..... from 1,5" to 20"
  - rim diameter ..... from 1" to 23"
  - Max. wheel/machine distance ..... 220 mm
  - Max. wheel width (with guard) ..... 510 mm
  - Max. wheel diameter (with guard) ..... 925 mm
  - Max. wheel weight ..... 65 kg
- Shipping weight (without accessories) ..... 157 kg
- Noise level when running ..... < 70 dB(A)



# MACHINE OUTFIT

The following parts are supplied together with the machine:

- Weight clip pliers ..... code 900203841
- Threaded hub ..... code 900222099
- Flange attachment bolt ..... code 900222101
- Caliper for wheel width measurement ..... code 900223420
- Weights identification plate ..... code 900437485
- Hex wrench CH 4 ..... code 900600714
- Hex wrench CH 5 ..... code 900600674
- Hex wrench CH 6 ..... code 900600906
- Hex wrench CH 10 ..... code 900600910
- 100 gram weight ..... code 900430573

## OPTIONAL ACCESSORIES

Please refer to relevant accessories catalogue.

# GENERAL CONDITIONS OF USE

The equipment is intended for professional use only.



**WARNING**

**Only one operator may work on the equipment at a time.**

The balancing machines described in this manual must be used **exclusively** to measure the entity and position of imbalances on motor vehicle wheels, within the limits specified in the technical specifications section. Furthermore, models with motors must be provided with a suitable guard, fitted with a safety device, which must be lowered during the spin operation.



**WARNING**

**All other uses, apart from those described, are to be considered improper and unreasonable.**



**WARNING**

**Starting the machine without the wheel clamping equipment is forbidden.**



**WARNING**

**Do not use the machine without the guard and do not tamper with the safety device.**



**ATTENTION**

**Cleaning or washing the machine with compressed air or jets of water is forbidden.**



**WARNING**

**Only original CORGHI equipment should be used during operation.**



**WARNING**

**Get to know your machine. The best way to prevent accidents and obtain top performance from the machine is to ensure that all operators know how the machine works.**

**Learn the function and location of all the commands.**

**Carefully check that all commands on the machine are working efficiently.**

**To avoid accidents and injury, the machine must be installed properly, operated correctly and serviced regularly.**

GB

# SWITCHING ON THE MACHINE

Switch on the machine using the switch on the front of the body (M, fig.4).

The balancing machine carries out a checking test, and if no anomalies are detected it gives a beep and shows the logo and the personalisation data, after which it awaits input of the geometrical data of the wheel.

The knob of the Kis (Enter key) can be turned to display the video page with the image of the imbalance values (fig.10); the initial active status will be:

- active balancing mode: dynamic (DYN);
- values displayed: 000 000;
- grams displayed in units of 5 (or 1/4 of an ounce);
- sensor value rounding active.

At this point, the user may set the data of the wheel to be balanced or select one of the programs available.

## GENERAL NOTES ON THE MAIN MENU

The graphics are based completely on icons (drawings which recall the function of the key) to be selected to activate the respective functions; to aid understanding there is also a status line, at the bottom of the screen, subdivided into three fields: description of the meaning of the icon selected (the one surrounded by the yellow frame) indication of the machine status (x1 / x5 ; g / oz) indication of the active environment (active program)

All these indications are in the language already selected.

The bottom of the monitor contains the icons (main menu, MM) subdivided into four groups :



- The first group, of three icons, contains the functions relating to the balancing process types.
- The second group, also of three icons, contains the UTILITY programs; in this group the user may enter three UTILITY programs of his choice (the procedures for inserting them are described in the operating procedures). The three icons shown above are simply an example.
- The third group, of two icons, offers the UTILITY functions (additional programs for use of the machine) and the SETTING functions (machine operation setting procedures).
- The fourth group, of just one icon, offers the Help function; if activated, it shows the information needed for work within the active procedure.

To select the desired icon, turn the KIS until the yellow frame is on the chosen icon, then press the knob down (Enter).

All the functions which do not appear in the Main Menu are grouped together in submenus (also of icon type) which open when the main icon is selected.

To access a submenu, select the main icon. Once the Kis has been pressed, a series of new icons appear above the selected icon. Now turning the KIS selects the icons of the submenu.

Once the submenu has been opened, the Main Menu icon is replaced by the Exit icon, which allows the submenu to be closed without making any selection. The subdivision and functions of the individual main menu icons are explained below:



**Dynamic (standard) balancing program:** recalls the conventional method of balancing a wheel on both sides.



**ALU dynamic balancing programs:** recalls the various procedures for balancing light alloy wheels, known as ALU programs.



**ALU 1P balancing program:** provides precise calculation of the balancing weights to be applied on the inner rim disc (adhesive weights).



**ALU 2P balancing program:** provides precise calculation of the balancing weights to be applied on the inside of the wheel (clip weights) and the inner rim disc (adhesive weights).



**ALU 1 balancing program:** provides statistical calculation of the balancing weights to be applied on the inner rim disc (adhesive weights).



**ALU 2 balancing program:** provides statistical calculation of the balancing weights to be applied on the inside of the wheel (clip weights) and the inner rim disc (adhesive weights).



**ALU 3 balancing program:** provides statistical calculation of the balancing weights to be applied on the inner part of the (inside and outside) of the rim (adhesive weights).



**ALU 4 balancing program:** provides statistical calculation of the balancing weights to be applied on the inside (clip weights) and on the outside of the inner part (adhesive weights) of the rim.



**ALU 5 balancing program:** provides statistical calculation of the balancing weights to be applied on the inner part (adhesive weights) and on the outside (clip weights) of the rim.



**Balancing programs for motorcycle wheels:** programs suitable for balancing the wheels of motorcycles.



**Dynamic balancing program for motorcycle wheels:** allows balancing of motorcycle wheels using clip weights on both sides.



**ALU balancing program for motorcycle wheels:** allows balancing of motorcycle wheels using adhesive weights on both sides.



**Static balancing program:** allows balancing of both motorcycle and car wheels on a single plane.



**Activates selection of the utility programs:** allows access (by displaying them) to the icons relating to the general utility programs for operation of the machine.



**Print:** activates the procedure for printout of the initial and residual imbalance data of one wheel.



**Complete print:** activates the procedure for printout of the initial and residual imbalance data of four wheels.



**Position search:** brings the wheel into the correct position for application of the weights on both sides in alternation.



**ROD:** if the machine is equipped with the specific optional accessory, this icon activates the procedure for measuring the roundness of the tyre and wheel.



**Optimisation:** activates the procedure for optimisation of the rotating weights.



**Sensitivity calibration:** activates the program for calibrating the measurements made by the balancing machine.



**Sensor calibration:** activates the program for calibration of the wheel dimension measurements made using the sensors.



**Recall other icons:** displays the second series of icons.

Second series of icons:



**Data bank:** depending on the type of vehicle chosen, this function displays the types of wheel centring available, while also providing a rating of the centring quality.



**Manual data input:** activates the procedure for manual input of the wheel's dimensional values.



**Spin counter:** displays the total and partial count of the wheel spins performed.



**Recall logo:** recalls the machine's initial logo to the screen.



**Working environments:** activates the icons for selection of the working environments.



**Connection to a Personal computer:** if the machine is enabled for this, activates data communication with a P.C.



**Service programs:** recalls the diagnostics programs, useful for the technical service.



**Activate setup program selection:** allows access, by displaying them, to the icons relating to the programs for setting the balancing machine's operating parameters.



**Company data setting:** activates the procedure for setting the data (name, address, etc.) of the user's company.



**Language setting:** activates the icons for entering the language in which the operating messages are required to appear.



**Imbalance unit of measurement setting:** activates the icons for selecting the unit of measurement and the rounding with which the imbalance values are to be displayed (grams / ounces).



**Automatic position research setting:** activates the icon for setting the preferential type of wheel position location at the end of the wheel spin; the wheel may be brought to the position where the counterweight is to be applied in three ways: two attempts, one attempt and function disabled.



**Clamping mode setting:** informs the wheel balance about the type of clamping system used, normal or pneumatic (QL). Used for correct display of the centring type in the data bank.



**Modify wheel spin counter:** program not available.



**Preferential program setting:** activates the procedure for setting of three preferential programs to be placed in the main icon bar.



**Help:** recalls the information linked to the current video page to the screen. If an error message is present, the first information recalled relates to the types of error which may occur. The instructions recalled with this icon are an addition to (and not a replacement of) this operator manual to all intents.

The other icons, which can be described inside the individual programs, will be described directly in the respective operating phases.

# WHEEL DATA INPUT

The machine acquires the diameter, distance and width values automatically. Bring the two automatic measuring arms (inside and outside) (A, B, fig.4) into contact with the two sides of the rim as shown in fig.11. The monitor shows the image relating to the geometrical dimensions of the wheel.

**Take the greatest care to position the arms correctly, in order to obtain an accurate reading of the data.**

Keep the arms in contact with the rim until the machine has acquired and displayed the wheel diameter, distance and width values.



Check the values obtained and then return the arms to the rest position.

If an incorrect value is acquired during the reading phase, return the arms to the rest position and then repeat the operation.

It is possible to make the measurements moving just one arm at a time; in this case, great care must be taken with regard to the data measured because they are affected by those already present in the memory.

After setting the geometrical dimensions correctly and returning the sensors to the rest position, the video shows the imbalance values recalculated on the basis of the new dimensions.

If the automatic measuring arm fails to operate, **the geometrical data can be entered in manual mode by following this procedure.**

- select the icon  in the utility submenu (  )

- the video page for manual setting of the data appears on the screen.

It contains the following icons:



**Enter width in inches:** enables entering of the rim width in inches.



**Enter width in millimetres:** enables entering of the rim width in millimetres.



**Enter diameter in inches:** enables entering of the rim diameter in inches.



**Enter diameter in millimetres:** enables entering of the rim diameter in millimetres. Use the special caliper to measure the width.



**Enter distance in millimetres:** enables entering of the distance between the rim and the machine body in millimetres.



**Exit:** returns the program to the video page with the imbalances.



**Help :** shows the help information relating to the manual setting of data.

- After selecting an icon, turn the Kis until the desired value appears in the box relating to the datum to be entered.
- Press the Kis knob to confirm the value
- Select a new icon to set another parameter
- To stop the manual data setting process, select the Exit icon.

The values to be set are the nominal values of the rim, while for the distance simply read the value indicated on the graduated rule of the sensor after bringing it into contact with the inside of the rim (fig.11a).

## WHEEL SPIN

Wheel spin takes place automatically when the guard is lowered, or can be triggered by pressing the START key (coloured green) with the guard lowered. A special safety device stops rotation if the guard is raised during the spin; in this case, the **Err Cr** message appears.

During position search, the wheel may spin with the guard raised.



**WARNING**

**Starting the machine without the guard and/or with the safety device incorrectly positioned or tampered with is forbidden.**



**WARNING**

**Never raise the guard before the wheel has come to a stop.**



**WARNING**

**If, due to a fault on the machine, the wheel keeps spinning permanently, switch off the machine at the master switch or unplug the plug from the power supply panel (emergency stop). Then wait until the wheel stops before raising the guard.**

# USING THE AUTOMATIC CLAMPING DEVICE

The procedure for using the machine is very similar to that of an ordinary balancing machine with fixed threaded hub.

## Centring with front cone

- Fit the wheel onto the shaft, sliding it on until it rests against the flange.
- Place the most suitable cone on the shaft and fit it into the hole in the centre of the wheel.
- Press the control pedal (N, fig.4a) so that the threaded hub moves outward.
- Fit the ring-nut, moving it along the threaded hub until it is touching the cone.
  
- Release the control pedal so that the threaded hub returns to the rest position, clamping the wheel against the flange.

## Centring with rear cone

- Fit the spring onto the shaft and place it inside the flange.
- Place the cone which provides the best fit for the hole in the centre of the wheel on the shaft.
- Place the wheel on the cone and slide it on until the cone is touching the spring.
- Press the control pedal (N, fig.4a) so that the threaded hub moves outward.
- Fit the ring-nut, moving it along the threaded hub until the plastic cap is touching the wheel rim.

Now apply pressure so that the spring is slightly pre-loaded.

- Release the control pedal so that the threaded hub returns to the rest position, clamping the wheel against the flange.

## Centring with flanges

- Fit the flange onto the shaft.
- Press the control pedal so that the threaded hub moves outward.
- Fit the special cap provided, then turn it clockwise.
- Release the pedal so that the cap clamps the flange onto the shaft.
- Clamp the wheel onto the flange in the normal way.

## N.B.

- In the fairly unlikely event that the control valve seizes or a compressed air connection line breaks, the machine is still able to operate like an ordinary balancing machine with fixed threaded hub. **This also allows the machine to be used if the compressed air supply fails and/or if the workshop's compressed air supply system breaks down.**
- In case of an operating error (e.g. if the release command is given while the wheel is still turning) the ring-nut ensures that the wheel cannot leave the shaft. In case of an error of this kind, the operator must abort the spin, clamp the wheel again and perform another spin.

GB

- The Quick Lock clamping system ensures virtually complete compatibility with all accessories supplied with balancing machines without automatic clamping devices.

## BALANCING PROGRAMS

The balancing programs are divided into groups represented by the first three icons of the main menu:

- standard dynamic balancing
- dynamic balancing of wheels with alloy rims
- dynamic and static balancing of motorcycle wheels.

Before starting a balancing operation, proceed as follows:

- fit the wheel on the hub using the most suitable flange; see the guidelines provided in the data bank ;
- secure the wheel so that no movements are possible during the wheel spin and braking phases;
- remove any balancing weights, stones, dirt or other foreign bodies from the wheel;
- enter the wheel data correctly.

### Dynamic balancing (STANDARD)

This balancing procedure is the one normally used and is considered standard by the balancing machine; if a different balancing program is on the screen,

select the icon  from the main menu.

The video page relating to this program appears on the screen (fig.10). Now proceed as follows :

1. Enter the wheel data correctly.
2. Spin the wheel by pushing down on the guard.
- To obtain the highest precision in the results, do not apply any undue stresses to the machine during wheel spin.**
3. wait for the wheel to stop automatically and for the imbalance values calculated to appear.
4. select the first side to be balanced.
5. turn the wheel until the central element of the corresponding position indicator illuminates.
6. apply the balancing weight indicated, in the position on the rim corresponding to 12 o'clock.
7. repeat the operations listed above for the second side of the wheel.
8. carry out another wheel spin to check the balancing precision. If this is not considered satisfactory, modify the value and position of the weights applied previously, following the guidance provided by the balance control diagram (fig.13).

Bear in mind that especially for large imbalances, an error in positioning of the counterweight of just a few degrees may lead to a residual imbalance as large as 5-10 grams during the verification phase.



## WARNING

**Check that the system which fits the weight to the rim is in optimum condition. A weight which is not properly or correctly fitted may come off as the wheel rotates, creating a potential danger.**

To simplify balancing weight application, the wheel can be kept braked in two ways :

- by pressing the pedal under the base, below the wheel to be balanced
- by pressing the **STOP** key when the wheel is in one of the weight application positions; the wheel is released by pressing the **STOP** key again, when a wheel spin is triggered, or after about 10 sec.

The shaft clamping system can also be useful during installation of special centring accessories.

Pressing the **STOP** key while the wheel is in motion interrupts the wheel spin before time.

If the "RPA" (position centred) program is active, at the end of each balancing wheel spin the machine stops the wheel in the position for application of the weight on the inside; if this balancing weight is equal to zero, the wheel is stopped in the position for the outside. If the **START** key is pressed with the guard raised, automatic search for the second side position begins.

This function is described in greater detail in the AUTOMATIC POSITION SEARCH section.

## Balancing aluminum (ALU) wheels

To balance aluminum wheels we usually use self-adhesive weights that are positioned differently from the clip weights used in standard balancing (fig. 14). There are various ALU balancing programs, specially designed to work with rims of this type.

These programs are recalled from the main menu using the icon,  which opens the submenu of seven icons in two groups: ALU P and normal ALU programs.

### ALU 1P and ALU 2P programs

These programs are used for maximum precision balancing on light aluminum rims that **require the application of both weights on the same side (inner) in relation to the rim disk.**

This type of balancing procedure is particularly suitable for applying adhesive weights to the rim, since the forward position of the wheel in relation to the machine body gives free access to a large zone on the inside of the rim.

After selecting the icon,  select one of the two icons relating to the ALU P programs.



ALU 1P



ALU 2P

The screen shows the video page for measuring imbalances on alloy wheels.

### Wheel data acquisition

With this program the real wheel data have to be set **in relation to the real balancing planes** rather than the nominal values (as in standard ALU programs). The balancing planes where the **adhesive** weights will be applied *can be selected by the user according to the particular shape of the rim*. It should be remembered, however, that in order to reduce the quantity of the weight that is to be applied **it is preferable to select balancing planes that are as far apart as possible**; if the distance between the two planes is less than 37 mm (1.5"), the "Err 5" message will be displayed.

- Move the end of the inner automatic sensor in correspondence with the plane chosen for application of the **inside** weight. In Alu 1 P, the centre of the groove on the end of the arm, in which the adhesive weight for application will be placed (fig.15a) is taken as reference. In Alu 2 P reference is made to the edge of the rim, since the inside weight is of the traditional clip-on type (fig.11a).

**Make absolutely certain that the end of the sensor is positioned in an area free of discontinuity, so that the weight can be applied in the same position.**

- Press the KIS knob to confirm acquisition of the data.
- Move the end of the automatic sensor in correspondence with the plane selected for the application of the outside balancing weight (fig.15b), in the same manner as described previously for the inside plane.
- Press the KIS knob to confirm acquisition of the data.
- Return the sensor to the rest position.

If the sensor is returned to the rest position after having only acquired the data for one plane, or if the outside plane data are acquired first, followed by the inside plane data, the "Err 23" message will appear on the video and the acquired data will not be taken into consideration.

- Carrying out a spin.

### Attaching balancing weights

- Select the plane where the first balancing weight is to be applied.
- Rotate the wheel until the central element of the corresponding position indicator is illuminated.

If the balancing weight is of the **traditional clip type** (inside plane in ALU 2P), position the balancing weight at **12 o'clock**. If, on the other hand, the weight is of the **adhesive type**:

- centre it inside the cavity in the weight holder end of the measuring arm (fig.16), with the backing paper of the adhesive strip facing up. Then remove the backing paper.
- Move the sensor until the two reference lines (in yellow) in the window provided on the screen.
- Rotate the end of the sensor until the weight adhesive strip is in position in correspondence with the rim surface.

- Press the push button (fig.16) to eject the weight and make it stick to the rim.
- Return the sensor to the rest position.
- Repeat this process for the application of the second balancing weight.
- Carry out a test spin to check the accuracy of the balancing.

In order to be sure that the weight sticks to the rim the surface must be perfectly clean. If necessary, clean the rim surface with a suitable detergent.

### **“Mobile planes” program (only available with ALU P programs)**

This function is automatically activated when an ALU P program is selected.

**It modifies the pre-selected positions for the application of adhesive balancing weights, in order to allow perfect wheel balancing using commercially available adhesive weights in multiples of five grams.** The precision of the machine is thereby improved, avoiding rounding or cutting weights in order to come closer to the real imbalance values.

The modified positions, where the adhesive weights are to be applied, are selected by the user according to the instructions supplied by the balancing machine (see ATTACHING BALANCING WEIGHTS section).



To avoid excessive and unnecessary delays, the calculations are carried out at the conclusion of the spin, excluding it at the moment of selection of the ALU P programs or after a new acquisition of wheel data. In this event, no imbalance values will be displayed.

Normally the machine modifies the position where the balancing weights are applied according to the criteria pre-established by the program. However, depending on the type of rim and according to the operator's discretion, the intervals within which the machine can modify each balancing plane can be defined. In order to perform this operation, two successive sets of wheel data must be acquired for each of the rim planes (see MEASURING WHEEL DATA section). The range of each interval cannot exceed 20 mm, in order to prevent the re-calculated planes from being positioned in areas of discontinuity on the rim and the calculation time from increasing excessively. If the second acquisition takes place with the sensor in excess of the maximum range, this acquisition will be taken as a reference to the second plane.

## “Hidden weight” program (only available on demand with ALU P programs)

This program sub-divides the outside balancing weight into two combining weights, located in a hidden position behind the two spokes on the aluminum rim.

- First select either the ALU 1P or the ALU 2P program; the selection is used

making the icons  (ALU programs) and then  (ALU 1P) or

 (ALU 2P).

- The **Hidden weight** icon  will appear on the icons bar instead of the motorcycle program selection icon.

- When this icon is selected, a window will appear on the screen.

- Turn the Kis to set the number of spokes in the rim to be balanced; the OFF message means that this function is not required.

- Bring a spoke to 12 o'clock and press the Kis knob; the number and position of the spokes has now been memorised.

- The imbalance is shown on the monitor, including the two position indicators for the outside plane. The imbalance value shown for this plane refers to the indicator in the centreed position condition.

The application of each of the two balancing weights is carried out as described in the ALU P programs “attaching balancing weights” section.

The HIDDEN WEIGHT function combines with the MOBILE PLANES function in order to allow to be used in multiples of 5 grams.

## Standard ALU programs (ALU 1, 2, 3, 4, 5)

The ALU standard programs take into account the different positions for the application of the weights (fig.14) and provide correct imbalance values **maintaining unchanged the nominal wheel data input for aluminum rims.**

To activate these programs, proceed as follows :

- select the icon  **ALU programs;**

- select one of the icons.



**ALU 1 balancing program:** provides statistical calculation of the balancing weights for application on the inner rim disc, as shown in the relative icon.



**ALU 2 balancing program:** provides statistical calculation of the balancing weights for application on the side and on the inner rim disc, as shown in the icon.



**ALU 3 balancing program:** provides statistical calculation of the balancing weights for application, as shown in the icon.



**ALU 4 balancing program:** provides statistical calculation of the balancing weights for application, as shown in the icon.



**ALU 5 balancing program:** provides statistical calculation of the balancing weights for application on the inner rim disc and the outside of the rim, as shown in the icon.

- Once a wheel spin has been performed, when the centred position is reached the screen indicates where the balancing weights have to be placed in relation to the program chosen.
- Enter the nominal geometrical data of the wheel. These data may be entered either in manual mode or using the automatic sensors; follow the procedures already described in ENTERING WHEEL DATA. If the values of the diameter and of the distance between the two balancing planes recalculated on a statistical basis starting from the geometrical data of the wheel are outside the normally accepted range stated in the TECHNICAL DATA, the message "Alu Err" is displayed.
- Perform a wheel spin and proceed as described for dynamic balancing. Some slight residual imbalance may remain at the end of the spin test due to the considerable difference in shape found in rims with the same nominal diameters. To counter this, change the amount and position of the weights in accordance with the "balance check" diagram (fig.13) until an accurate balance status has been obtained.

## Motorcycle wheel balancing

Motorcycle wheels can be balanced in:

- dynamic mode; when the width of the wheel is such (over 3 inches) to generate significant imbalance components which cannot be eliminated with static balancing (the recommended procedure).
- dynamic mode for alloy wheels ; a program similar to the ALU programs for car wheels, with the possibility of dividing the weight for one side into two parts when particularly bulky spokes are present
- static mode; just one balancing weight, perhaps divided into two equal parts on two sides; procedure described in the STATIC BALANCING section.

GB

### Motorcycle dynamic program

To balance a motorcycle wheel on two planes (dynamic balancing) using clip weights, proceed as follows:

- fit the motorcycle wheel adapter (AUMO) on the balancing machine as shown in figure 17.
  - insert the two screws provided in the holes on the wheel support flange;
  - screw the screws onto the adapter, taking care that it is resting correctly on the flange;

- fit the most suitable pin (this depends on the hole in the centre of the wheel) onto the shaft, after removing the threaded hub;
- mount the wheel after choosing the centring cones (one each side of the wheel) and tighten with the ring-nut provided, using the spacers needed to obtain continuity between the clamping cones and the threaded part of the shaft.

**IMPORTANT:** For accurate measurements, it is essential to fix the wheel to the flange in such a way that no reciprocal movement is possible between the two elements during wheel spin or braking.

- Select the icon  **Motorcycle wheel balancing programs.**

- Now select the icon  **Motorcycle wheel dynamic balancing programs;**

- the image relating to this program appears on the screen.
- Fit the special extension (A, fig. 17) on the internal measuring arm. Remember to remove this extension before performing the wheel spin.
- Set the wheel data in the usual way.
- Proceed as described for dynamic balancing.

### **Motorcycle ALU program**

For dynamic balancing of motorcycle wheels with adhesive weights proceed as follows:

- Follow the instructions for installation of the motorcycle wheel adapter given in the MOTORCYCLE DYNAMIC PROGRAM section.

- select the icon  **Motorcycle wheel balancing programs;**

- select the icon  **Motorcycle wheel ALU balancing program.**

When the centred position is reached, the corresponding balancing planes will appear on the rim displayed on the video screen.

Proceed as described previously for the “**Motorcycle Dynamic**” program; the imbalance values are calculated and displayed on the basis of the real weight application position.

To obtain the best results, the adhesive weights should be applied with their outermost edge against the edge of the rim.

Some rims have extra wide spokes, close to which adhesive weights cannot be applied; to solve this problem, a program which divides the counterweight into two parts has been provided.

In this case, when the centred position is reached, if it is noted that the balancing weight has to be applied where there is a spoke, proceed as follows:

- remain in centred position state;

- select the icon  **Divide weight for side** (displayed instead of the “select ALU programs” icon);

- turn Kis to select the spoke size in the window which appears; small, medium, large or OFF (disables this setting procedure);
- confirm by pressing the Kis;
- apply the two new counterweights in the positions indicated.

The weight division operation can be carried out on both sides of the wheel.

### Static balancing

A wheel can be balanced by applying a single counterweight on one of its sides or in the centre of the well; in this case, the wheel is balanced statically. However, there is still the risk of dynamic imbalance, which becomes more significant as the width of the wheel increases.

To balance motorcycle wheels in static mode, proceed as follows:

- follow the instructions for installation of the motorcycle wheel adapter given in the MOTORCYCLE DYNAMIC PROGRAM section.

- select the icon  **Motorcycle wheel balancing programs;**

- select the icon  **Static balancing program;**

now the image displayed shows just one position search.

Proceed as described previously for the “**Motorcycle Dynamic**” program; for your information, note that in this balancing mode the width and distance values are of absolutely no importance.

- Apply the balancing weight at 12 o'clock, on the outside, the inside or in the well (this makes no difference at all). If applied in the well, the weight is applied on a diameter smaller than the nominal diameter of the rim, so in order to obtain correct results a value of 2 or 3 inches less than the nominal value must be entered when the diameter is set.

To obtain the best results, divide the weight in two and apply it to both sides of the rim.

This type of balancing can also be carried out on car wheels; in this case, do not follow the instructions for fitting the motorcycle wheel adapter, but use the procedure for fitting a car wheel.

GB

# FLASH OPT OPTIMISATION PROGRAM

This program has been made even simpler and faster than other types of Flash OPT program; in most cases, the results obtained can be compared with those of the Standard program described below, using fewer wheel spins and therefore speeding up the procedure.

For guidance on this procedure, refer to the next section, bearing in mind that the flash version of the program must not be accessed until a wheel spin has been performed.

The Flash OPT program automatically skips the first phase with the rim only (OPT 1) and the start of the procedure is indicated by Flash OPT.

The calculations made by this program are based on the imbalance values obtained during the last wheel spin performed; for this reason, the last spin must have been carried out with the wheel on which the quick optimisation procedure is to be used.

## OPT 1

- Turn the wheel until the valve is at 12 o'clock.

- Select the  icon to memorise the position of the valve.

## OPT 2

See OPT3 of the Standard OPT program.

## OPT 3

See OPT4 of the Standard OPT program.

# OPT OPTIMIZATION PROGRAM (OPTIONAL)

This procedure is used to reduce **road noise** (vibrations) to a minimum. Road noise can still be present even after a very painstaking balancing, but it can be reduced by eliminating any mismatch between tyre and rim as much as possible. The professional experience of the tyre specialist is extremely important in these cases. If it is decided that this extra step could be helpful to reduce road noise to a minimum, this program can be selected.

However, the machine indicates whether or not this procedure is recommended by

means of a special window which appears when the  **Optimisation** icon is selected; the decision is based on the imbalance values obtained during the

last wheel spin performed, which must therefore have been carried out with the wheel to be optimised.

To recall this program, proceed as follows:

- select the  **Utility programs** icon;

- select the  **Optimisation** icon;

this accesses the first phase of the program.

## OPT 1

- Fit **the rim** on the machine **without the tyre**.
- Turn it until the valve (or hole, although it is preferable to work with the valve already fitted) is at 12 o'clock.

- Select the  icon to memorise the position of the valve.

- Perform a wheel spin.

At the end of the spin, the system moves on to the second phase of the program.

## OPT 2

- Take the rim off the machine.
- Fit the tyre on the rim.
- Fit the complete wheel on the machine.
- Turn it until the valve is at 12 o'clock.

Select the  icon to memorise the position of the valve.

Perform a second wheel spin.

At the end of the spin, the system moves on to the third phase of the program.

### OPT 3

Following the instructions on the monitor:

- turn the wheel until the valve is at 6 o'clock (the arrow at the bottom changes from yellow to green);
- make a chalk mark on the outside wall of the tyre at 12 o'clock;

confirm that the mark has been made by selecting the  icon.

The image on the screen now changes.

- Take the wheel off the machine.
- Turn the tyre on the rim until the mark made previously is in line with the valve (rotation through 180°).
- Put the wheel back on the machine.

Then following the new instructions on the monitor:

- Turn the wheel until the valve is at 12 o'clock.

- Select the  icon to memorise the position of the valve.

- Perform a third spin.

The system now displays the real imbalance values of the wheel in its current position on the balancing machine.

Bring the wheel into the position indicated. The monitor will display the 2 imbalance values and the percentage improvement which can be obtained if the user decides to continue with the optimisation procedure.

If the improvement already obtained is not considered sufficient, or if no

significant improvements are possible, the user can select the  **Exit** icon

and perform a spin to balance the wheel; otherwise, the system moves on to the fourth and final phase of the program.

### OPT 4

Following the instructions on the monitor:

- turn the wheel until it is in the position shown by the position indicator ;
- Make a **double chalk mark** on the **outside** wall of the tyre at 12 o'clock. If the screen indicates that the tyre should be mounted on the rim the other way round, make the two chalk marks on the **inside** of the tyre wall.
- Remove the wheel from the balancing machine.
- Rotate the tyre (switching around if necessary) on the rim, until the mark made previously corresponds with the valve (rotation through 180°).
- Re-fit the complete wheel on the balancing machine.

Following the instructions on the right hand part of the monitor:

- Rotate the wheel until the valve (or hole) is at 12 o'clock.

- select the  icon to memorise the position of the valve.

- Carry out the fourth spin.

With the completion of the fourth spin, the optimization program has been completed and the weights to be added to balance the wheel will be displayed on the monitor.

If an error has been made that may negatively affect the end result, the machine will indicate this error with the "Err 6" message. This means that the entire procedure should be repeated from the beginning. The error message will disappear when one of the available functions is selected.

### Special cases

1. If the user does not wish to perform the spin with rim only, the first phase can be skipped. To do this, after selecting the OPT program, activate the



**Skip first OPT phase icon.** Then fit the wheel complete with tyre on the

balancing machine and carry out the other phases (2, 3 and 4) as previously described. The results obtained are less precise than those provided by the complete procedure.

2. At the end of the second or third spin, the screen may show the OUT 1 and OUT 2 messages, respectively

In this case, it is advisable to exit from the program by selecting the



**Exit icon.**

The values of the weights necessary to balance the wheel will appear on the screen.

This shortens the procedure, which means doing without a modest improvement in the final results; however, it is possible to continue with the optimisation procedure.

3. At the end of the third spin, the screen may inform the user that the tyre should be fitted on the rim the other way round. If the user does not wish to do this, or

if it is not possible, the



**Disable tyre reversal icon** should be

selected; the machine will provide the instructions for completion of the program without reversing the tyre.

The



**Enable tyre reversal icon** reactivates the reversal function.

4. The user can exit from the optimisation procedure at any moment by simply

selecting the



**Exit icon.**

5. If a different working environment is recalled between one phase of the OPT procedure and the next, on return to the OPT environment performance of the procedure restarts from the point where it was interrupted.

# UTILITY PROGRAMS

Utility programs are all functions of the balancing machine which are useful for its operation but not closely linked to normal use.

To display the list (menu) of utility programs, simply select the



**Utility**

**programs** icon; the icons corresponding to this submenu are now accessible.

## Recall other icons

The utility programs contain a large number of functions, and therefore, for reasons of clarity, the icons have been divided into two groups, displayed separately. This



**Recall other icons** icon is used to display the two groups of icons in

alternation.

## Sensitivity calibration

This program should be run whenever the settings appear to be out of tolerance or when the machine requests self-calibration spontaneously by displaying the "Err 1" message.

After obtaining the menu of balancing programs on the display, proceed as follows:

- select the



**Sensitivity calibration** icon;

- Select a wheel **of average size and weight (e.g.: 5"x14") preferably with a limited imbalance**, and fit to the shaft.
- Enter the correct wheel data.
- Rotate the wheel to the point denoted by the position indicator and by the appearance of the value "100" ("3.5" if the 'ounce' mode is selected).
- Attach the 100 g (or 3.5 oz.) sample weight to the **OUTSIDE** of the rim, exactly at 12 o'clock position.
- Carry out a spin.
- Once the wheel has stopped, remove the sample weight and rotate the wheel to the point denoted by the position indicator and by the appearance of the value "100" ("3.5" oz.).
- Attach the 100 g (or 3.5 oz.) sample weight to the **OUTSIDE** of the rim, exactly at 12 o'clock position.
- Carry out a second spin.

If the calibration program has been completed successfully, this will be confirmed by a message of approval. If not the "Err 3" message will be displayed. In this case the calibration should be repeated correctly, checking that the weight used actually corresponds to 100 g ("3.5" oz.).

The self-calibration program ends with the display showing the imbalance values for the wheel (ignoring the sample weight).

## NOTES



- Remember to **remove the 100 g (3.5 oz.) weight** at the end of the procedure.
- Performance of the program can be interrupted at any moment by pressing **EXIT**.

**THE CALIBRATION DESCRIBED ABOVE IS VALID FOR ANY TYPE OF WHEEL!**

### Sensor calibration

This procedure is used to calibrate the automatic measuring arms. It must be carried out whenever the machine requests it by displaying the message Err 4, or when there is a discrepancy between the geometrical values obtained and the actual values of the wheel.

After displaying the list of utility programs:

- select the  **Sensor calibration** icon;
- fit a steel wheel of **average size (e.g. 5"x14")** on the balancing machine;
- check the nominal values of the rim on the top line of the monitor; if the values are incorrect, select the  icon and set the new data as explained in the "entering wheel data" section;
- bring the two automatic sensors to the rest position (fully retracted for the inside one and fully extended for the outside one).

- select the  **Confirm sensor calibration** icon to confirm the position of the sensor;
- bring the inside sensor into contact with the rim in the usual dimension acquisition position, as shown in fig.11a;

- select the  **Confirm sensor calibration** icon to confirm the position of the sensor;
- return the inside sensor to the rest position;
- bring the outside sensor into contact with the rim in the usual dimension acquisition position, as shown in fig.11b;

- select the  **Confirm sensor calibration** icon to confirm the position of the sensor.

Sensor calibration is now complete.



### ATTENTION

**It is essential to set the diameter and width values corresponding to the rim mounted on the balancing machine correctly. Any errors in this phase will affect all subsequent diameter measurements.**

If the calibration operation has been completed successfully, this will be confirmed by a message of approval. If not the "Err 20" message will be displayed, indicating that the sensor was incorrectly positioned during the calibration phase. In this case the sensor should be positioned correctly and the calibration procedure should be repeated, as previously described.

The  **Exit** icon can be selected to exit from the program without performing calibration.



### ATTENTION

**It should be remembered that the nominal diameter of the wheel (e.g.: 14") refers to the tyre bead contact surfaces inside the rim. The value shown, on the other hand, refers to the external planes and is therefore less than the nominal values as a result of the thickness of the rim. This difference is compensated for by the sensor calibration procedure, in order to make the values shown correspond with the nominal values - which constitute a consolidated point of reference for the user. The compensation is obviously carried out in reference to the thickness of the rim used during the calibration procedure, therefore the data shown for wheels with different thicknesses may present slight differences (maximum 2 or 3 tenths of inches) in relation to the nominal values. This does not represent a lack of precision, but rather a reflection of the real situation.**

## Spin counter

After obtaining the utility menu on the display, proceed as follows:

- Select the  **Spin Counter** icon.

A window will be displayed on the video showing the values of the two counters:

- the first value shows the number of spins carried out since the machine was last switched on (when the machine is switched off, this value is zero-set);
- the second value shows the number of spins that the machine has carried out in its entire operational lifetime.

To eliminate display of the counters, press Kis  (**Exit** is the only icon active).

## Initial display recall

At any time the initial display with the personalized data can be recalled.

After displaying the list of the utility programs, select the  **Recall logo**

icon.

This display will appear automatically, after periods of machine inactivity, even if the function has not been directly requested. To return to the previous operating status, move the KIS.

## Service

This program displays the data that is used to test the operation of the machine and identify any malfunctions on the machine devices. This data is of no practical use to the user and should only be used by technical assistance personnel.

### Vehicle data bank

The machine controls a data bank with which it is capable of indicating the best centring values for clamping each wheel to the shaft.

This function is extremely useful as the use of the appropriate accessories for centring the wheel is the most important factor for accurate wheel balancing.

After having visualized the utility menu on the display, proceed as follows:

- select the  **Data bank** icon .

- A list of makes of vehicle will appear on the video. Select the name corresponding with the vehicle that requires wheel balancing;

- turn the Kis to select the desired make;

- select "**another page**" to display more makes of car;

- select "**exit**" to leave the program.

After selecting the make, select the model of the vehicle by following the same procedure.

Once the vehicle has also been selected, the screen shows a video page comprising:

- the name of the vehicle;

- the optimum centring mode for that type of wheel;

- the diameter of the wheel's central hole;

- the number of holes for fixing the wheel to the vehicle and the diameter on which these holes are located.

There are also two icons (in addition to the usual exit and help icons); their functions are:



#### **Display another centring type; recall other centring modes.**

The system is able to indicate up to three types of centring for every single wheel, together with their degrees of efficiency.



**Select new vehicle;** recalls the list of makes of vehicle to allow a new selection to be made.

To exit from the data bank program, select the  **Exit** icon.

## Automatic position search (RPA)

It is possible to switch from one centred position to the other by selecting the



**Position search** icon; whenever this icon is selected, the system switches

from the centred position of one side to that of the other.

This function is only active if it is enabled in the settings.

## Working environments

This balancing machine allows three different operators to work at the same time, thanks to its three different working environments.

- To recall a working environment, select the  **working environment** icon.

after displaying the list of utility programs.

- A submenu appears on the right, displaying three different working environments (operator 1,2,3).

The yellow selection rectangle is located on the current operator.

- Turn the KIS to move the selection rectangle onto the operator required and press to make the selection.

When a new operator is selected, the machine restores the parameters active at the time of the latest recall.

The parameters which can be saved are:

- balancing mode; dynamic, alu x, motorbike, etc.

- Wheel dimensions: distance, diameter and width or those relating to the ALU active.

- OPT; last OPT passage.

The general machine settings remain the same throughout all the working environments: grams/ounces, sensitivity x5/x1, threshold, etc.

## Partial printout

Activated by means of the  **Print** icon; program not available.

## Total printout

Activated by means of the  **Complete print** icon; program not available.

## Run-out detection

This program allows extremely accurate detection of wheel roundness defects and supplies guidance for combining the rim and the tyre so that the shape defect is as small as possible.

**For performance of this procedure, the special optional ROD device (A, fig.18) must be installed.**

Before selecting the program:

- Enter the diameter of the wheel rim on which the detection procedure is to be performed;
- clean the wheel and the inside edge of the rim at all the detector contact points, to ensure that localised roughness will not reduce the accuracy of the measurements.

After displaying the list of utility programs:

- select the  **ROD** icon to access the “**Run-out detection**” program;
- if the message “Err Rot” appears, turn the wheel by hand until the ROD program video page appears.

### Standard procedure

#### Phase 1

- Fit the wheel on the balancing machine;
- turn it until the valve is at 12 o'clock;
- Select the  icon to memorise the valve position.

#### Phase 2

- Release the ROD device using the lever provided (B, fig.18);
- turn the support of the detector roller so that the roller is on the right of the detector rod;
- bring the roller (C, fig.18) into contact with the tyre near its centre line, preloading it until the green area of the position indicator on the screen illuminates;
- lock the ROD device in this position by releasing the control lever. Make sure that the preload remains correct with the device locked;

- select the  icon to acquire the preload value;
- turn the wheel in the normal rotation direction (clockwise) by hand until the run-out graph appears in the top of the screen;
- evaluate the degree of run-out on the basis of the bands shown on the graph; the narrowest band (green) indicates one millimetre, the middle-sized one (orange) two millimetres, and the widest one (red) four millimetres.
- The mobile indicator on the graph indicates the wheel run-out for the 12 o'clock position, allowing direct inspection of wheel run-out defects.

GB

### Phase 3

- Release the ROD device and bring the roller into contact with the inside of the rim, preloading it until the green area of the position indicator on the screen illuminates;
- lock the ROD device in this position by releasing the control lever. Make sure that the preload remains correct with the device locked;

- select the  icon to acquire the preload value;

- turn the wheel by hand, **anti-clockwise** this time, until two more graphs appear on the screen.

The central graph relates to the rim run-out, while the bottom one displays the residual run-out which remains on the wheel after the tyre has been turned on the rim to minimise this defect.

### Phase 4

If only a modest improvement can be obtained, the video shows the message “OUT” to offer the option of exiting from the program without turning the tyre on the rim. Otherwise, to obtain the ideal mounting position:

- turn the wheel until it is in the position shown by the indicator on the left of the last graph;
- make a chalk mark on the **outside** of the tyre at 12 o'clock;
- remove the wheel from the balancing machine;
- turn the tyre on the rim until the mark made earlier is in line with the valve; this is the maximum wheel roundness which can be obtained by partially compensating the defects of the tyre with those of the rim, and corresponds to the roundness shown on the third graph.

On completion, the user may:

- print out the results by selecting the  **Print** icon (if the optional printer is present);

- repeat the procedure from the beginning by selecting the  **Repeat measurement** icon;

- exit from the program by selecting the  **Exit** icon.

### Special cases:

- The rim run-out can be measured directly without first acquiring the tyre run-out.
- To do this, access the “**Run-out detection**” program and proceed as follows:

- select the  **Skip to rim run-out measurement** icon;
- proceed as described in phase 3 above; the video will show the graph for the rim only.

- At the end of phase 2, acquisition of the tyre run-out value can be repeated with the device placed at a different point from that used previously.

To do this:

- select the  **Repeat measurement** icon;
- proceed as described in phase 3 above.

The standard procedure involves a measurement made at the median circumference of the tyre (with reference to its width), but run-out defects are not normally identical at the different points: inside wall, centre line, outside wall. This means it may be useful to make a series of measurements in the points on the tyre referred to above; the machine will display a graph obtained by processing all the information acquired, thus supplying a more correct overall result.

- The user can exit from the program at any moment by selecting the



**Exit** icon.

On completion of the operations, return the detector to the rest position using the control lever and turn the roller support through half a turn so that the roller will not interfere with the sensor arm.

### Connection to Personal Computer

Activated by means of the



**Connection to Personal computer** icon;

program not available.

GB

# SETTINGS

The setting programs comprise the functions which personalise operation of the balancing machine and are normally used on installation.

To display the list (menu) of setting programs, simply select the

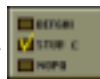

**Setting**

**programs** icon; now the icons corresponding to this submenu are available:

## Personalisation

This program allows the user to memorise a number of data as desired, such as: name, town, street, telephone number, advertising slogans, etc.

The data will then be displayed on the first video page and in the printout.

After displaying the list of setting programs:

- select the  **company data setting** icon.

- The screen shows a video page where the data can be set, comprising:

- 5 lines on which the data can be typed (in the top left-hand corner of the screen);
- a keyboard for setting the characters;
- 6 icons for the commands;
- 1 exit from program icon;
- 1 Help icon.

- Turn the Kis to select the character to be typed.

- Confirm the selection by pressing the Kis.

The command icons are:



**Move to next line;** used to shift the cursor onto the line after the current line.

If there is already a word on the new writing line, it will automatically be deleted.



**Move to previous line;** used to shift the cursor onto the line before the current line. If there is already a word on the new writing line, it will automatically be deleted.



**Delete last character entered;** moves the cursor one place to the left, deleting the character present.



**Set upper/lower case;** selects upper and lower case characters alternately.

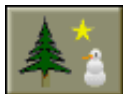

**Enable/next printer drawing;** shows the sequence of drawings which can be reproduced in printouts (one drawing at a time).



**Disable drawing in printout;** annuls printout of any drawing selected.

The data set are memorised when the user exits from the program, i.e. when the



**Exit** icon is selected.

Users are advised to set their name and surname on the first line, the name of their town on the second, their street on the third and their telephone number on the fourth, with the advertising slogan on the last two lines.

## Language

The language of the machine messages that appear on the monitor can be selected.

After obtaining the setting programs menu on the display, proceed as follows:

- select the  **language setting** icon;

- the screen shows a list of flags, e.g.  (English),  (German),

 (Italian);

- select the flag corresponding to the language required; in case of doubt, the name of the language activated by the flag chosen can be seen in the bottom right-hand corner of the screen ;
- press the Kis to activate a language.

It is only possible to exit from this program by selecting a language, after which the image of the imbalances reappears on the screen.

The  icon allows a new group of icons to be recalled to the screen.

GB

## Imbalance display in grams/ounces

This sets the unit of measurement (grams or ounces) and the rounding (x1, x5 or x1/4, 1/10) with which the imbalance values are displayed.

After the list of setting programs has been displayed, proceed as follows:

- select the  **Imbalance unit of measurement setting** icon.

The following icons appear on the screen:



**Set grams x1**; displays the imbalance values gram by gram;



**Set grams x 5**; displays the imbalance values 5 grams by 5 grams;



**Set tenths of an ounce**; displays the imbalance values in steps of one tenth of an ounce;



**Set quarters of an ounce**; displays the imbalance values in steps of a quarter of an ounce.

- Select the display mode desired and press the Kis knob.

After the selection, the new setting is memorised and the image of the imbalances reappears on the screen.

## Automatic position search setting

Enables/disables and sets automatic positioning of the wheel at the end of the spin. The user can set the maximum number of attempts for automatic search for the position for application of the balancing weights.

After displaying the list of setting programs, proceed as follows:

- select the  **Set automatic position search (RPA)** icon.

The following icons appear on the screen:



**Set RPA2**; enables the procedure for wheel positioning with error correction; if the first attempt is not successful, the wheel will be rotated again;



**Set RPA1**; enables the rapid wheel positioning procedure;



**Disable RPA**; disables the wheel positioning procedure.

- Select the desired setting and press the Kis knob.  
After selection, the new setting is memorised and the image of the imbalances reappears on the screen.

### Clamping type

This sets the type of blocking system used on the balancing machine: manual (STD) or pneumatic (Q.L.).

This setting is used to provide the data bank with the correct information.

After displaying the list of setting programs, proceed as follows:

select the  **Set clamping type** icon.

The following icons appear on the screen:



**Set manual clamping;** enables the data bank information relating to manual wheel clamping;



**Set Quick Lock clamping;** enables the data bank information relating to quick (pneumatic) wheel clamping.

- Select the icon relating to the equipment on the balancing machine and press the Kis knob.

After the selection, the new setting is memorised and the image of the imbalances reappears on the screen.

### Number of spins

The icon of reference is  **Modify spin counters.**

Function not available.

### Setting preferential programs

This function allows the user to set three icons of his choice in the main icons bar.  
After displaying the list of setting programs, proceed as follows:

- select the  **Set preferential programs** icon;
- the screen shows the list of all the utility program icons (see this chapter for the functions of the individual icons);
- select the three icons in the order in which they are required to appear, from left to right;
- the system exits from the program on selection of the third icon.

To exit from the program without changing the current settings, select the  **Exit** icon.

GB

# ERROR MESSAGES

The machine can recognize a certain number of incorrect operations and will signal them with appropriate messages on the display.

**Err 1** Error in first sensitivity calibration.

The sensitivity calibration procedure should be carried out.

**Err 3** Error in the execution of the sensitivity calibration procedure.

Make sure that the sample weight has been applied and repeat calibration.

**Err 4** Sensor calibration error.

The sensor calibration procedure should be carried out.

**Err 5** Incorrect wheel data for aluminum wheel balancing program.

Correct the dimensions set.

**Err 6** Error made during the OPT procedure (optimization).

Repeat the procedure from the beginning.

**Err 7** The machine is temporarily unable to select the program requested.

Carry out a spin and repeat the request.

**Err 8** Printer out of service; printer not present; printer failure.

**Err 9** Imbalance value exceeds 999 grams.

Reduce the imbalance and repeat the spin.

**Err 10** a) Internal distance sensor not in rest position (completely in) when the machine is switched on.

Switch off the machine, return the sensor to its correct position and switch on again.

b) Potentiometer malfunction. Select the



**Manual data input**

icon to disable the sensors and enter the data by hand.  
Call in the technical service.

**Err 11** Diameter potentiometer malfunction. Select the



**Manual data**

**input** icon to disable the sensors and enter the data by hand.  
Call in the technical service.

**Err 12** Width potentiometer malfunction. Select the



**Manual data input**

icon to disable the sensors and enter the data by hand.  
Call in the technical service.

**Err 20** Sensors in incorrect position during calibration.

Bring them to the position indicated and repeat the calibration.

**Err 23** Incomplete or incorrect data entered in ALU P.

Repeat acquisition process correctly.

**Err 25** Program not available on this model.

**Err 27** Wheel did not stop within the maximum allowed time.

If this message appears frequently contact your service centre.

**Err 28** Encoder error. If this message appears frequently contact your service centre.

- Err 29** Wheel spin device failure. Try moving the wheel by hand; if the fault does not disappear, call in the technical service.
- Err 30** Failure on wheel spin device. Switch off the machine and call in the technical service.
- Err 31** Optimisation procedure already started by another user.
- Cr Err** Spin carried out with wheel guard up. Lower the guard in order to carry out the spin.

## BALANCING ACCESSORY AVAILABILITY STATUS

This check allows the user to make sure that wear has not altered the mechanical specifications of flanges, cones, etc., beyond the specified limits.

The test is carried out with a perfectly balanced wheel (to zero without the threshold and showing the first gram). When this wheel is mounted on the balancing machine, removed and remounted in a different position, the imbalance weight should not be more than 10 grams.

If the imbalance is higher, check all the accessories with care and replace any that show dents, abnormal wear, bent flanges, etc.

Always remember that if you are using a cone to centre the wheel on the shaft, you will never obtain good results if the hole in the rim is not perfect, i.e.: off-centre or out-of-round. Results are always better when the wheel is centred with the rim holes.

It should be remembered that any difference between the way the wheel is mounted on the vehicle and the way it is mounted on the balancing machine will undoubtedly generate a certain degree of imbalance.

This can only be eliminated with "on vehicle balancing", using a finishing balancing machine to complement the work on the bench balancing machine.

# TROUBLESHOOTING

Listed below are faults that the user can remedy if the cause is found to be among those indicated.

Any other defect or malfunction will require the attention of a qualified technician: contact your nearest Corghi service centre.

## **The machine fails to switch on (the monitor remains off and there is no light showing at the main switch)**

### **No power at the socket**

- ➔ Check the mains power is present.
- ➔ Check the electrical power circuit installed in the workshop.

### **Defective machine plug**

- ➔ Check that the plug is undamaged.

## **The machine fails to switch on (the monitor remains off even with the light showing at the main switch)**

### **One of the FU1 ÷ FU6 fuses of the transformer has blown**

- ➔ Replace the blown fuse.

### **The FU1 power supply fuse has blown (LED L2 and L5 are off)**

- ➔ Replace the blown fuse.

### **The monitor has not been switched on (only after installation)**

- ➔ Switch on the monitor by pressing the push button on the monitor front panel (behind the black frame on the front level window).

### **The monitor power supply connector (located on the rear part of the monitor) has not been correctly inserted**

- ➔ Check that the connector is correctly inserted.

## **The diameter and width values acquired with the automatic sensors do not correspond to the nominal values of the rims.**

### **The sensors have not been correctly positioned during measurement**

- ➔ Bring the sensors to the position shown in fig.11 and follow the instructions in the ENTERING WHEEL DATA section.

### **The sensors have not been calibrated**

- ➔ Carry out the sensor calibration procedure.

### **The thickness of the rim is different from that of the wheel used for sensor calibration (if the difference is no more than one inch)**

- ➔ The measurement is correct because it considers the actual diameter for application of the weights. See precautions in the SENSOR CALIBRATION section.

### **The automatic sensors do not work.**

**Fuses FU2 and FU3 of the power supply adaptor have blown (LEDs L1 and L3 are off and the potentiometer values displayed in Service mode are constantly zero)**

- ➔ Replace the fuses.

**The sensors were not in the rest position at switch-on (Err 10) and the**



**manual data entering icon has been selected, disabling control of the automatic sensors**

- ➔ Switch the machine off, bring its sensor into the correct position and switch it back on.

### **The wheel fails to spin when the START control is activated (the machine does not start).**

**The wheel guard is raised**

- ➔ Lower the wheel guard (CrErr is displayed).

**The FU2, FU3 and FU4 power supply fuses have blown (LED lights L1 and L3 are off).**

- ➔ Replace the blown fuses.

### **The machine displays unsteady imbalance values.**

**The machine has been jolted during the spin**

- ➔ Repeat the spin, taking care not to disturb the machine while measuring is in progress.

**The machine is not soundly installed on the flooring**

- ➔ Check the installation and adjust the support feet, using shims if necessary.

**The wheel is not properly clamped**

- ➔ Tighten the clamping ring-nut firmly.

### **Several spins are required in order to balance a wheel.**

**The machine has been jolted during the spin**

- ➔ Repeat the spin, taking care not to disturb the machine while measuring is in progress.

**The machine is not soundly installed on the flooring**

- ➔ Check the installation and adjust the support feet, using shims if necessary.

**The wheel is not properly clamped**

- ➔ Tighten the clamping ring-nut firmly.

**The machine is not correctly calibrated**

- ➔ Carry out the sensitivity calibration procedure.

**The geometrical data are not correct**

- ➔ Check that the data corresponds to the dimensions of the wheel and correct, if necessary.
- ➔ Carry out the sensor calibration procedure.

# MAINTENANCE



## WARNING

**CORGHI declines all liability for claims deriving from the use on non-original spares or accessories.**



## WARNING

**Before carrying out any adjustments or performing maintenance operations, disconnect the electrical power supply from the machine and make sure that all moving parts are suitably immobilized.**



## WARNING

**Do not remove or modify any parts of the machine except in the event of service interventions.**



## ATTENTION

**Keep the work area clean.**

**Do not clean the machine with compressed air or jets of water.**

**When cleaning the area take steps to avoid raising dust as far as possible.**

- Keep the balancing machine shaft, the clamping ring-nut, the cones and the centring flanges clean. Clean using a brush dipped in environmentally friendly solvents.
- Handle cones and flanges with care to avoid the risk of dropping them and causing damage that would affect centring precision.
- When not in use, store cones and flanges in a place where they are protected from dust and dirt.
- Use ethyl alcohol to clean the level window.
- Calibrate the machine at least once every six months.

# SCRAPPING

If the machine is to be scrapped, remove all electrical, electronic, and plastic components and dispose of them separately, as provided for by local legislation.

## RECOMMENDED FIRE-EXTINGUISHING DEVICES

When choosing the most suitable fire extinguisher consult the following table:

	<b>Dry materials</b>	<b>Inflammable liquids</b>	<b>Electrical fires</b>
Water	<b>YES</b>	NO	NO
Foam	<b>YES</b>	<b>YES</b>	NO
Dry chemical	YES*	<b>YES</b>	<b>YES</b>
CO <sub>2</sub>	YES*	<b>YES</b>	<b>YES</b>

YES\* *Use only if more appropriate extinguishers are not on hand and when the fire is small.*



### WARNING

**The indications in this table are of a general nature. They are designed as a guideline for the user. The application of each type of extinguisher will be illustrated fully by the respective manufacturers on request.**

GB

# GLOSSARY

Following there is a brief description of some of the technical terms used in this manual.

## **BALANCING CYCLE**

Sequence of operations performed by the user and the machine, starting from the beginning of the wheel spin, to the time that the wheel is braked to a standstill after the unbalancing signals have been acquired and the relative values calculated.

## **CALIBRATION**

See SELF-CALIBRATION

## **CENTRING**

Procedure for positioning the wheel on the spin shaft with the aim of ensuring that the rotation axis of the wheel is aligned with the centre of the shaft.

## **CONE**

Conical components with centre hole which, when inserted on the spin shaft, serves to centre wheels with centre holes whose diameter is between maximum and minimum values.

## **DYNAMIC BALANCING**

Operation in which imbalance is corrected by the application of two weights, one on each side of the wheel.

## **FLANGE (Balancing machine)**

Disk that mates with the disk of the wheel mounted on the balancing machine. The flange also serves to keep the wheel perfectly perpendicular to its axis of rotation.

## **FLANGE (centring accessory)**

Device serving to support and centre the wheel. Also keeps the wheel perfectly perpendicular to its axis of rotation.

The centring flange is mounted on the balancing machine shaft by means of its central hole.

## **ICON**

Video representation of a key with graphics indicating the relative command.

## **IMBALANCE**

Non-uniform distribution of the wheel mass that results in the generation of centrifugal force during rotation.

## **SELF-CALIBRATION**

A procedure whereby suitable correction coefficients are calculated by starting from known operating conditions. Self-calibration improves the measurement precision of the machine by correcting, within limits, calculation errors that may arise due to alteration of the machine's characteristics over the course of time.

## **SENSOR (Measuring arm)**

Mobile mechanical element that measures geometric data (distance, diameter, width) when placed in contact with the rim in a pre-defined position. The data can be measured automatically if the sensor is fitted with the relevant measurement transducer.

**SPIN**

Procedure starting from the action that causes the wheel to rotate and the successive free rotation of the wheel.

**SPINNER**

Device for clamping the wheel to the balancing machine. The spinner features elements for engaging to the threaded hub, and lateral pins that are used to tighten it.

**STATIC BALANCING**

In static balancing only the static component of the imbalance is corrected. This is achieved by fitting a single weight - usually at the centre of the rim channel. The accuracy of this system increases as the width of the wheel decreases.

**THREADED HUB**

Threaded part of the shaft that is engaged with the spinner to clamp the wheel. This component is supplied disassembled from the machine.

# GENERAL ELECTRIC LAYOUT DIAGRAMS

**Fig. 19**

AP1	Power supply and controls board	RP4	REB potentiometer
AP2	Mother board (CPU)	RP5	ROD potentiometer
AP3	Keyboard	RP6	Voice synthesis volume potentiometer
AP4	Monitor	SA1	Switch
AP5	Search board	SB1	START button
AP6	Printer	SB2	STOP button
AP7	PWM board	SB3	Brake button
AP8	Memory expansion board	SB4	ENTER button
AP9	Voice synthesis board	SQ1	Safety guard microswitch
AP10	Display board	SQ2	START microswitch
AP11	Alphanumeric display piloting board	SQ3	Brake pedal microswitch
AP12	Optic sensor board	SQ4	Wheel spin device safety microswitch
B1	Speaker	SQ5	STOP microswitch
BP1	Internal pick-up	ST1	Motor overload cutout
BP2	External pick-up	TC1	Power supply transformer
BR1	Encoder	V1	Diode
C1	Capacitor	VC1	Diode rectifier
EVI	Fan	XB1	Connector
FU..	Fuse	XS1	Power supply socket
KM1	Remote switch	XT1	Terminal board
M1	Motor	YA1	Motor coil
QS1	Master switch	YA2	Brake / motor disconnection coil
QS2	Three-pole reverser	YV1	Wheel spin solenoid valve
R1	Resistor	YV2	Brake solenoid valve
RP1	Internal distance potentiometer	Z1	Mains filter
RP2	Diameter potentiometer	Z2	Motor filter
RP3	External distance potentiometer		

# 1

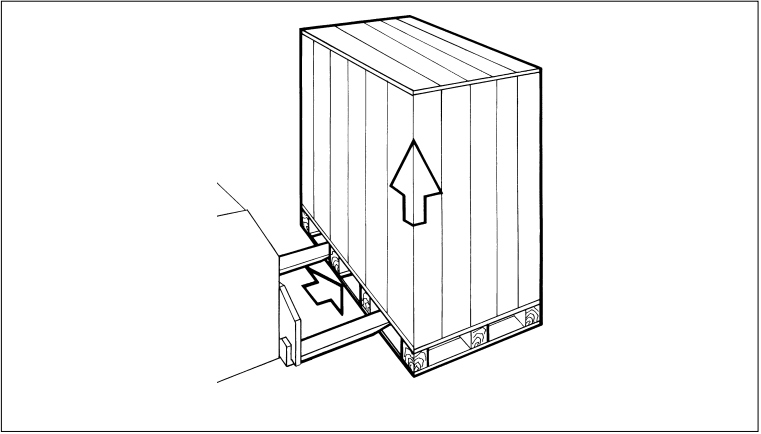

# 2

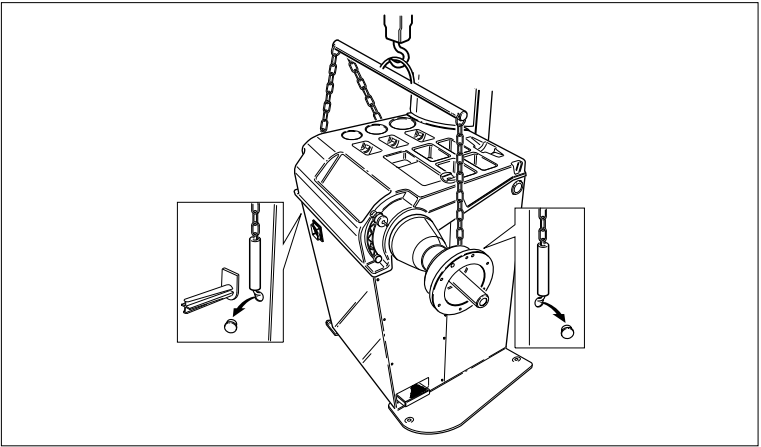

# 3

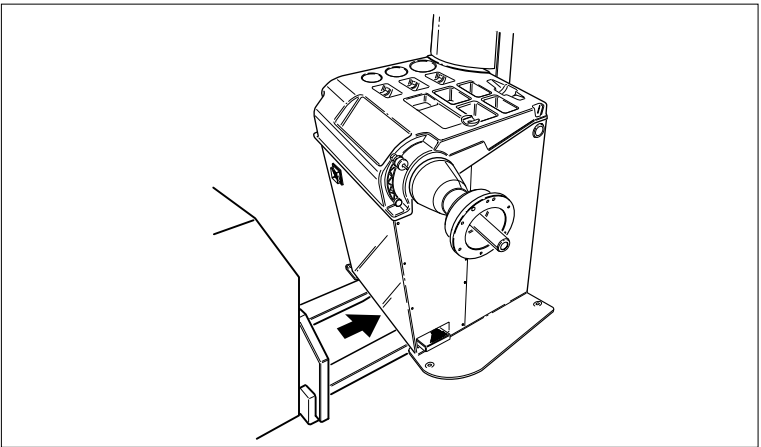

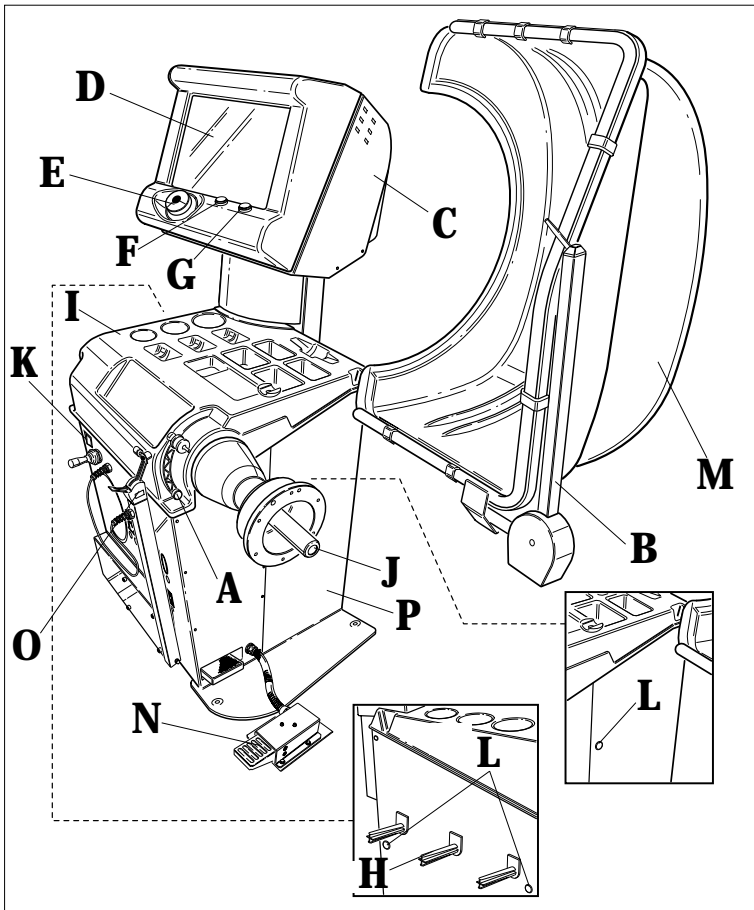

4a

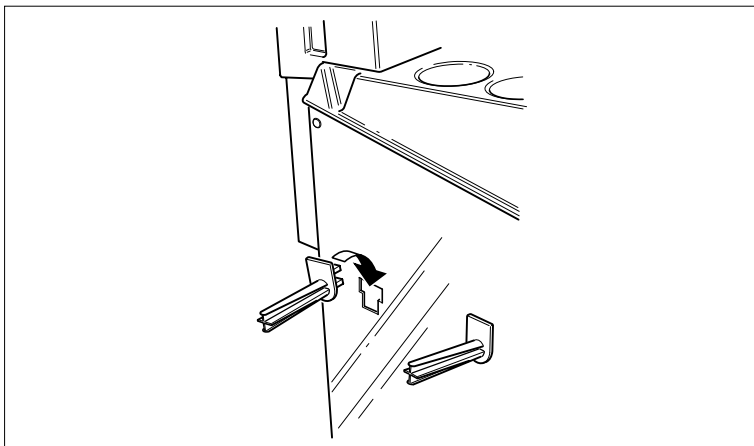

4b

5a

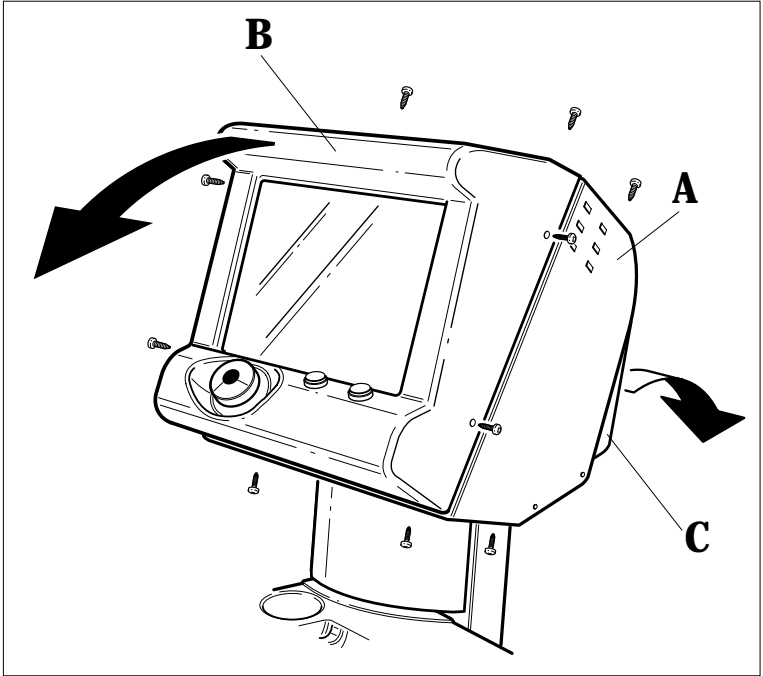

5b

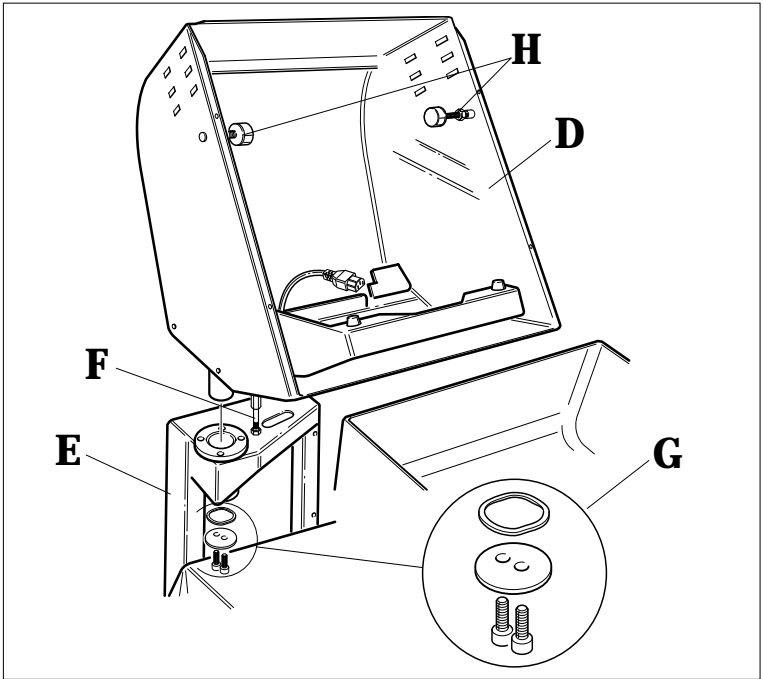

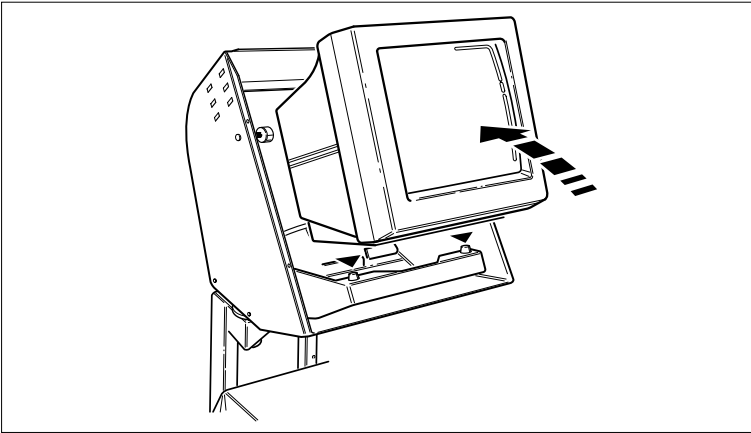

5<sub>c</sub>

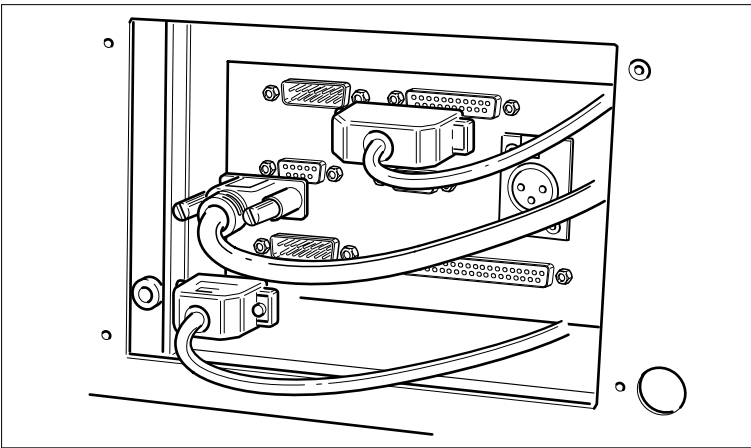

5<sub>d</sub>

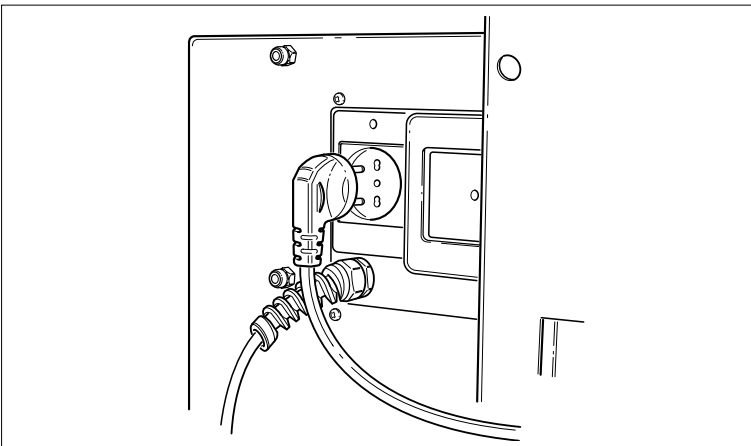

5<sub>e</sub>

6a

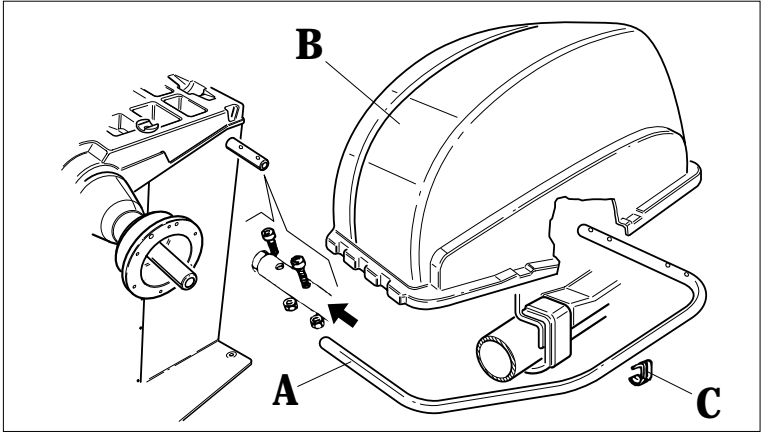

6b

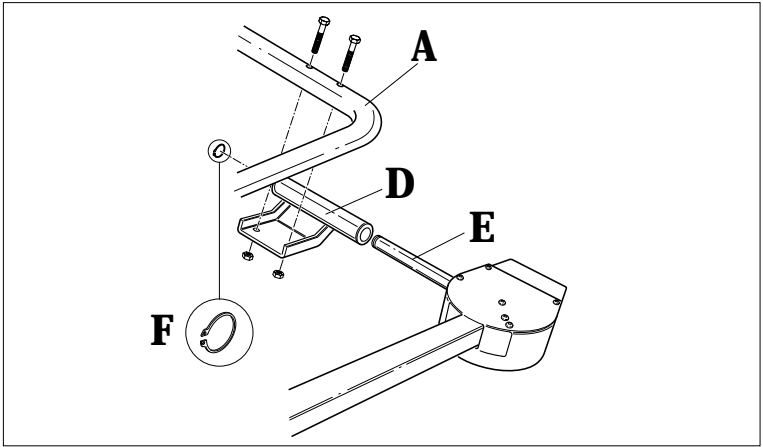

7

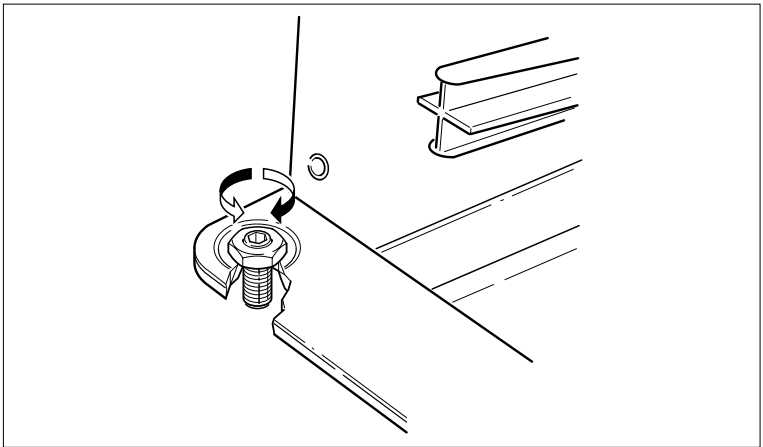

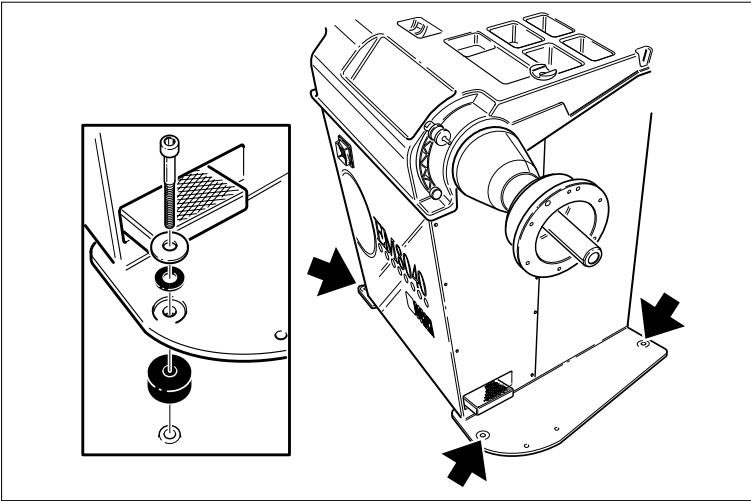

7<sub>a</sub>

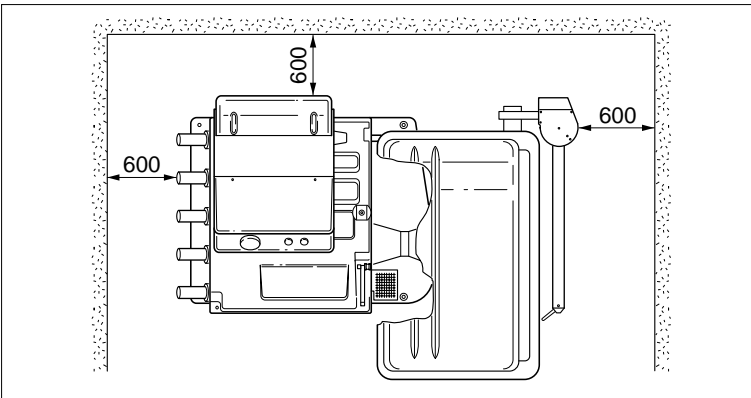

8

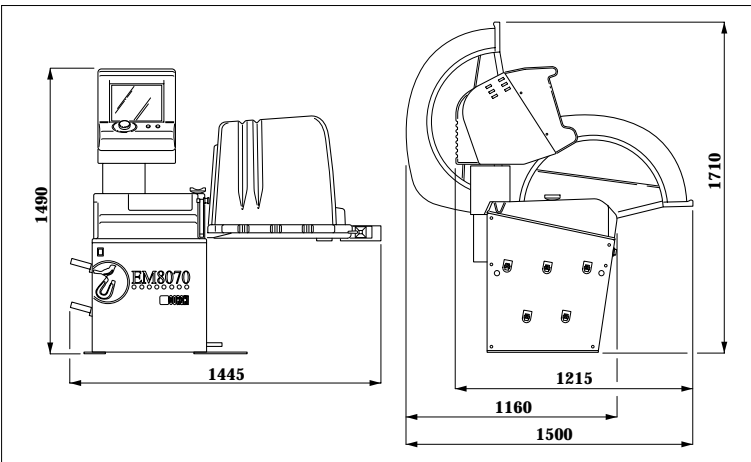

9

10

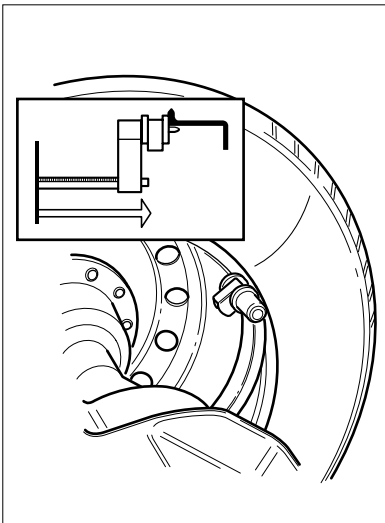

11a

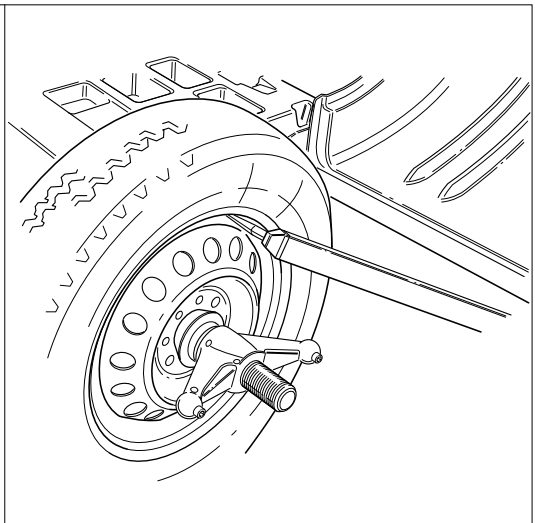

11b

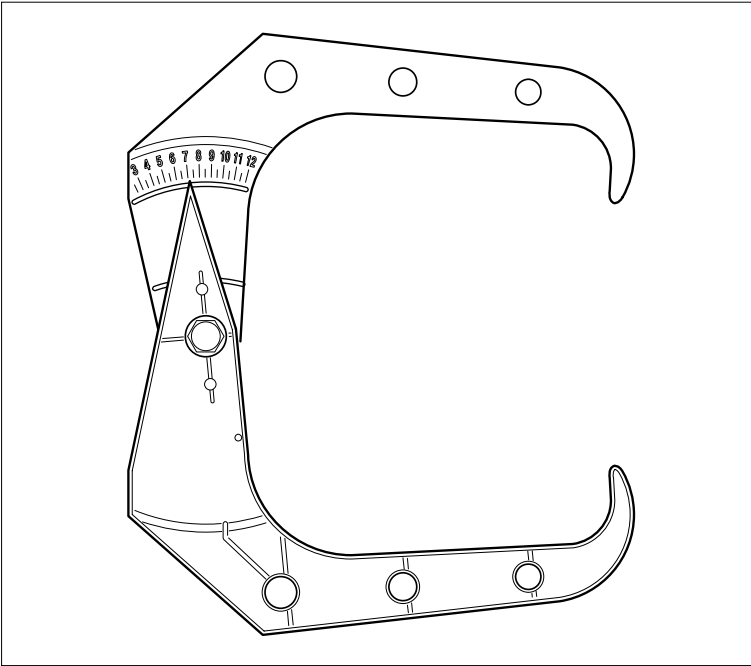

# 12

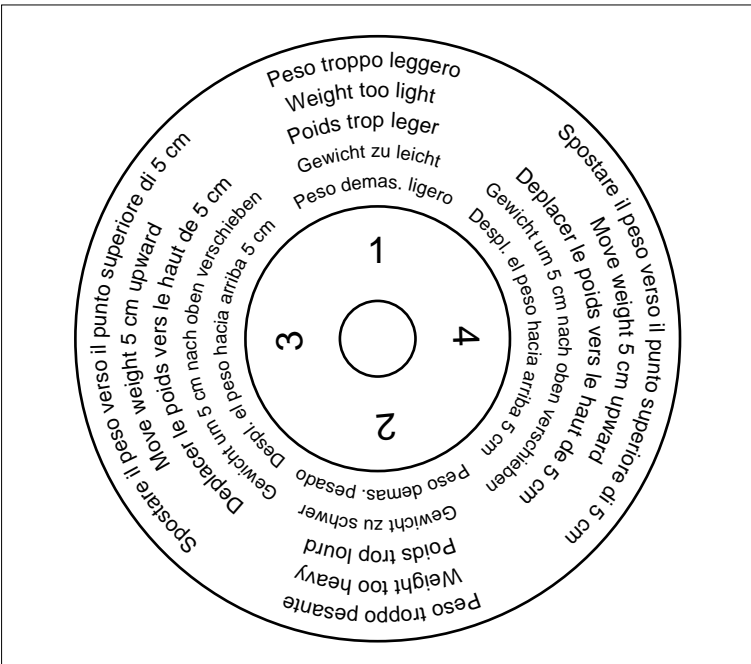

# 13

14

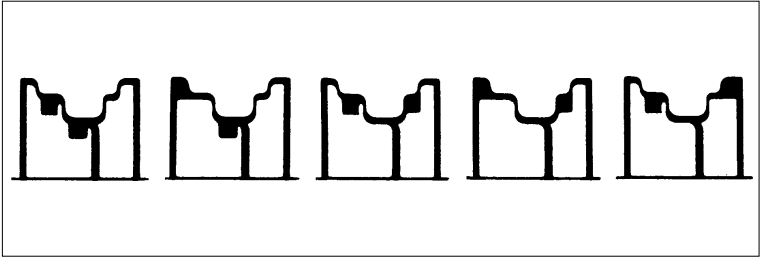

15a

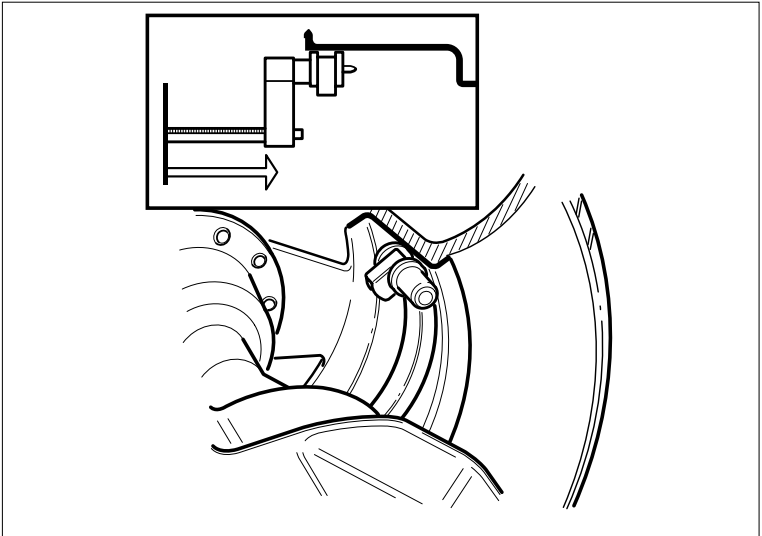

15b

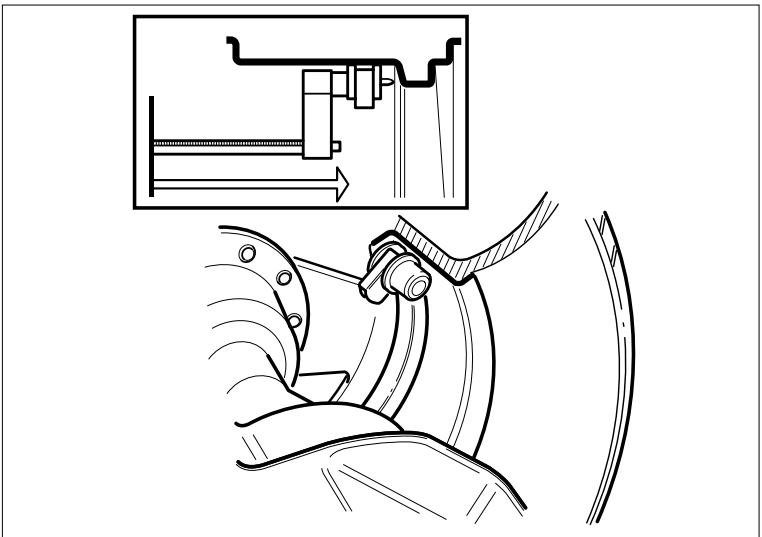

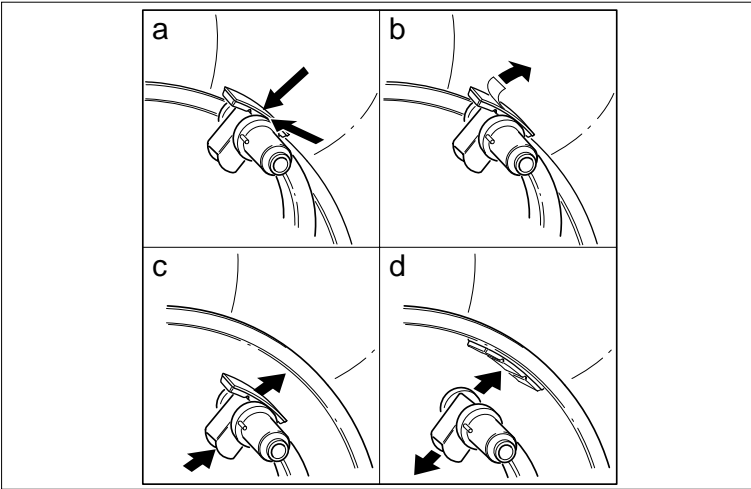

16

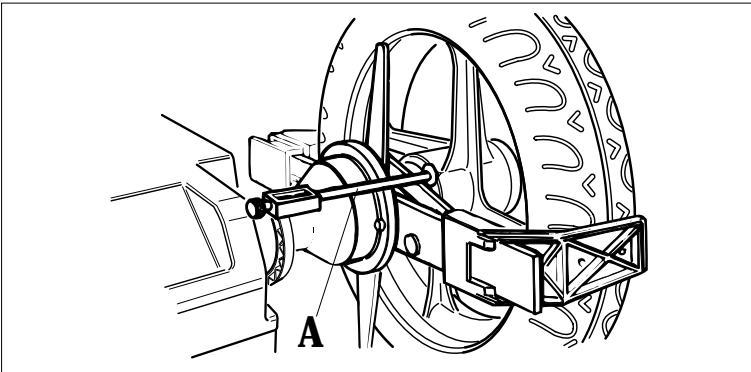

17

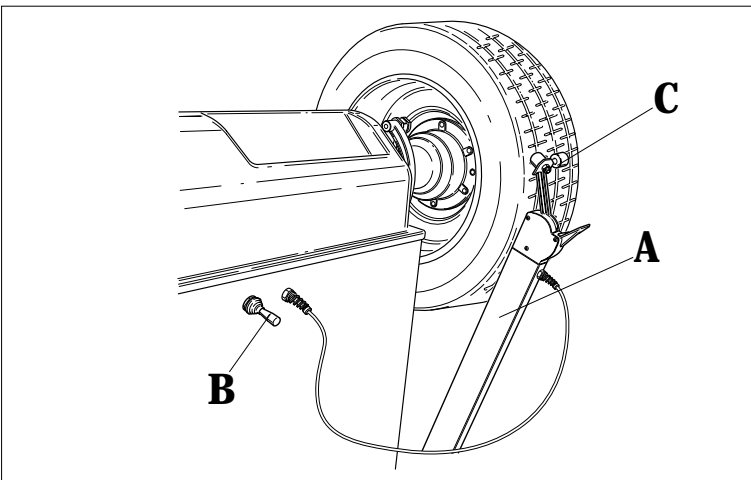

18

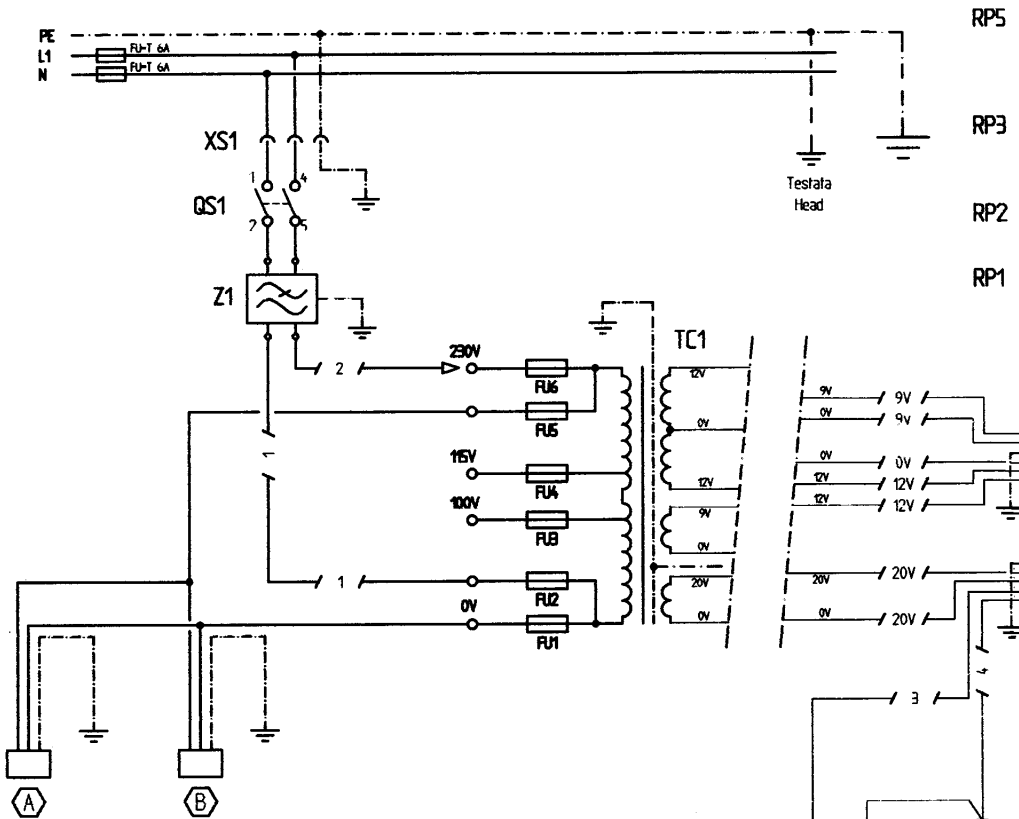

Fusibili - Fuses

	TC1	AP1	AP9
FU1	T 5A	3.15A	T 200mA
FU2	T 5A	500mA	T 200mA
FU3	T 5A	500mA	T 1A
FU4	T 5A	T 20A	T 3.15A
FU5	T 3.15A	4A	
FU6	T 3.15A	4A	



## EC statement of conformity

We, CORGHI SPA, Strada Statale n°9, Correggio (RE), ITALY, do hereby declare, that the product

### EM 8070 wheel balancer

to which this statement refers, conforms to the following standards or to other regulatory documents:

EN 292 of 09/91

according to directives:

- 89/392/EEC amended with directives 91/368/EEC, 93/44/EEC and 93/68/EEC;
- 89/336/EEC amended with directive 92/31/EEC.

Correggio, 02 / 02 / 98



.....  
CORGHI S.p.A.  
M. Frattesi

**IMPORTANT: The EC Conformity Declaration is cancelled if the machine is not used exclusively with CORGHI original accessories and/or in observance of the instructions contained in the user's manual.**

The form of this statement conforms to EN 45014 specifications.

## Déclaration CE de conformité

Nous, CORGHI SPA, Strada Statale 468, n° 9, Correggio (RE) Italy, déclarons que le matériel

### équilibruse EM 8070

objet de cette déclaration est conforme aux normes et/aux documents légaux suivants:

EN 292 du 09/91

Sur la base de ce qui est prévu par les directives:

- 89/392/CEE modifiées par les directives 91/368/CEE, 93/44/CEE et 93/68/CEE;
- 89/336/CEE modifiées par la directive 92/31/CEE.

Correggio, 02 / 02 / 98



.....  
CORGHI S.p.A.  
M. Frattesi

**IMPORTANT : La déclaration CE de conformité est considérée comme nulle et non avenue dans le cas où la machine ne serait pas utilisée exclusivement avec des accessoires originaux CORGHI et/ou, dans tous les cas, conformément aux indications contenues dans le Manuel d'utilisation.**

Le modèle de la présente déclaration est conforme à ce qui est prévu par la EN 45014.

## CE - Konformitätserklärung

CORGHI SPA, Strada Statale 468, Nr. 9, Correggio (RE), ITALY, erklärt hiermit, daß das Produkt

### Auswuchtmaschine EM 8070

worauf sich die vorliegende Erklärung bezieht, den Anforderungen folgender Normen und/oder normativer Dokumente entspricht:

EN 292 vom 09.91

auf Grundlage der Vorgaben durch die Richtlinien:

- 89/392/EWG mit Änderung durch die Richtlinien 91/368/EWG, 93/44/EWG und 93/68/EWG;
- 89/336/EWG mit Änderung durch die Richtlinien 92/31/EWG.

Correggio, 02 / 02 / 98



CORGHI S.p.A.  
M. Fratesi

**WICHTIG: Die CE-Konformitätserklärung verliert ihre Gültigkeit, falls die Maschine nicht ausschließlich mit CORGHI-Originalzubehör und/oder unter Mißachtung der in der Betriebsanleitung aufgeführten Gebrauchsanweisungen verwendet wird.**

Das Modell der vorliegenden Erklärung entspricht den Anforderungen der in EN 45014 aufgeführten Vorgaben.

## Declaración CE de conformidad

La mercantil CORGHI SpA abajo firmante, con sede en Strada Statale 468 n°9, Correggio (RE), Italia, declara que el producto:

### equilibradora EM 8070

al cual se refiere la presente declaración, se conforma a las siguientes normas y/o documentos normativos:

EN 292, de septiembre de 1991

a tenor de lo dispuesto en la Directiva:

- 89/392/CEE, modificada por las Directivas 91/368 CEE, 93/44/CEE y 93/68/CEE;
- 89/336/CEE, modificada por la Directiva 92/31/CEE.

Correggio, 02 / 02 / 98



CORGHI S.p.A.  
M. Fratesi

**IMPORTANTE: La declaración de conformidad CE deja de tener validez en el caso en que la máquina no sea utilizada exclusivamente con accesorios originales CORGHI y/o, en cualquier caso, con arreglo a las indicaciones contenidas en el Manual de Empleo.**

El modelo de la presente declaración se conforma a lo dispuesto en la EN 45014.

## Dichiarazione CE di conformità

Noi CORGHI SPA, Strada Statale 468 n°9, Correggio (RE), ITALY, dichiariamo che il prodotto

### **equilibratrice EM 8070**

al quale questa dichiarazione si riferisce è conforme alle seguenti norme e/o documenti normativi:

EN 292 del 09/91

in base a quanto previsto dalle direttive:

- 89/392/CEE modificata con le direttive 91/368/CEE, 93/44/CEE e 93/68/CEE;
- 89/336/CEE modificata con la direttiva 92/31/CEE.

Correggio, 02 / 02 / 98



.....  
CORGHI S.p.A.

M. Frattesi

**IMPORTANTE:** La dichiarazione CE di conformità decade nel caso in cui la macchina non venga utilizzata unicamente con accessori originali CORGHI e/o comunque in osservanza delle indicazioni contenute nel Manuale d'uso.

Il modello della presente dichiarazione è conforme a quanto previsto nella EN 45014.



CORGHI S.p.A. - Strada Statale 468 n.9  
42015 CORREGGIO - R.E. - ITALY  
Tel. ++39 0522 639.111 - Fax ++39 0522 639.150  
www.corgchi.com - info@corgchi.com